

CUKUROVA GENERATOR SYSTEMS

1500 Rpm, 50Hz, 400V

Perkins 1006TAG diesel engine

Newage/Stamford UCI274E alternator

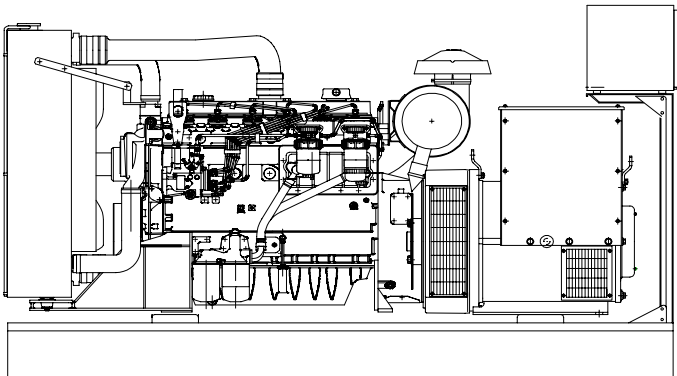

Standard Generator Features

- ◊ AMF, Automatic mains failure unit
- ◊ Heavy duty type, 6 cylinder, water cooled engine
- ◊ 50°C tropical type radiator
- ◊ Starter motor
- ◊ Lead acid battery
- ◊ Charging alternator
- ◊ Battery charge redressor
- ◊ Heavy duty, brushless type alternator
- ◊ Base frame with anti-vibration units
- ◊ Industrial type silencers
- ◊ Flexible exhaust compensator
- ◊ Block water heater unit
- ◊ Control panel with digital-automatic main control module
- ◊ Fan, fan drive, charging alternator drive and all rotating parts covered
- ◊ Radiator matrix covered by metal mesh against the mechanical damages
- ◊ Fabricated and welded steel base frame
- ◊ Anti-vibration mountings
- ◊ Engine and alternator manufacturer test reports
- ◊ Factory load, performance and function tests

Optional Features

- ◊ Automatic load transfer panel
- ◊ Automatic synchronization and power sharing systems
- ◊ Soundproof canopy
- ◊ Container type enclosures
- ◊ Road trailer
- ◊ Job-site trailer
- ◊ Protection circuit breaker
- ◊ Air start
- ◊ Remote type radiator
- ◊ Base fuel tank
- ◊ External type fuel tank
- ◊ Automatic fuel transfer system
- ◊ Residential silencer

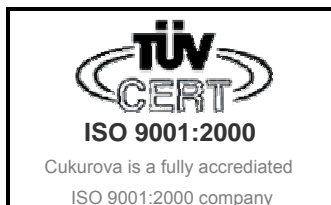

| Model | Standby | | Prime | |
|----------------|------------|------------|------------|------------|
| | kVA | kW | kVA | kW |
| CJ150PN | 150 | 120 | 139 | 111 |

APPLICATION DATA

Perkins 1006TAG Engine

Standard Features

Economic Power

- ◊Single side servicing for reduced service time and cost.
- ◊Unique Fastarm combustion system enables high power output plus low fuel consumption.
- ◊Electronic governor gives close control

Clean, Efficient Power

- ◊Operator and environmentally friendly with low noise, rapid startability and low emissions that satisfy **TA Luft** requirements.

Durable Power

- ◊Maximum cooling efficiency is provided by gear driven water pump and independent fan drive.
- ◊Leak free operation is ensured by Viton crankshaft seals and sophisticated controlled swell joints, giving protection in the toughest conditions.
- ◊Inserted valve seats, oil spray cooled pistons and compact plate cooler give enhanced engine life.

Reliable power

- ◊Wherever a Perkins' Electropak engine is put into service, it will never be far from the support provided by a global network of 4000 distributors and dealers, all backed by a part distribution centre giving 24 hours service, 365 days a year.

Technical Specifications

| | |
|---|--|
| Manufacturer | PERKINS |
| Model | 1006TAG |
| Type | 4 cycle, water-cooled, diesel engine |
| Number of cylinders | 6 |
| Cylinder arrangement | Vertical In-line |
| Displacement, Liters | 5.99 |
| Bore X Stroke, mm | 100 X 127 |
| Compression Ratio | 17.0:1 |
| Combustion System | Direct injection |
| Aspiration | Turbocharged, air to air charge cooled |
| Rotation | Clockwise viewed from the front |
| Gross engine power, kWb | 141 |
| Fan Power, kWm | 7.5 |
| BMEP gross, bar | 19.64 |
| Combustion air flow, m ³ / min | 8.78 |
| Exhaust gas temp.(after turbo), °C | 585 |
| Exhaust gas flow (after turbo),m ³ / min | 25.71 |
| Mean piston speed, m / s | 6.35 |

Cooling System

| | |
|--|---------------------------|
| Type | Tropical, heavy duty type |
| Ambient temperature, °C | 50 |
| Engine+Radiator coolant cap., Liters | 37.22 |
| Pressure cap setting, kPa | 68.9 |
| ◊Thermostat controlled cooling system with gear driven water pump. | |
| ◊Fan drive and 25" pusher fan | |
| ◊Radiator and piping with fan guards incorporating air-to-air charge cooler. | |

| Model | Standby kW | | Prime kW | |
|----------------|------------|--------------|--------------|------------|
| | Gross | Net | Gross | Net |
| 1006TAG | 141 | 133.5 | 128.4 | 121 |

Lubricating System

| | |
|--------------------------------|-------------|
| Type | Pressurized |
| Capacity, Liters | 19 |
| Lub oil pressure (min), kPa | 300-340 |
| ◊Flat bottomed aluminium fan | |
| ◊Spin-on full flow oil filters | |
| ◊Oil cooler | |

Fuel System

| | |
|--|-------------------------------------|
| Type of injection system | Direct injection |
| Fuel atomiser | Bosch/RSU/4 hole (0.35 mm diameter) |
| Fuel injection Pump | Rotary/Stanadyne DB4 |
| Delivery/hour at 1500rev/min, Liters | 122.4 |
| Governor type | Electronic, Perkins LCS2 |
| ◊Electronic governor speed control to ISO5514 classA0, ISO3046-4M3 | |
| ◊Rotary type fuel injection pump | |
| ◊Twin spin-on full flow oil filters | |
| ◊Cold start aid | |

Electrical System

| | |
|---|-----------------|
| Alternator | 12 Volt, 55 Amp |
| Starter motor (DC) | 12 Volt |
| ◊Oil pressure switch and coolant temperature switch | |
| ◊12 volt shut off solenoid energised to run | |

Fuel Consumption

| | | |
|-----------------|-----------|-----------|
| liters per hour | %110 Load | 34.6 L |
| | %100 Load | 31.5 L |
| | %75 Load | 24.1 L |
| | %50 Load | 16.5 L |
| grams per kWh | %110 Load | 206 g/kWh |
| | %100 Load | 206 g/kWh |
| | %75 Load | 210 g/kWh |
| | %50 Load | 215 g/kWh |

Newage/Stamford UCI274E Alternator

Standard Features

Winding&Electrical Performance

All generator stators are wound to 2/3 pitch. This eliminates triplen (3rd, 9th, 15th...) harmonics on the voltage waveform and is found to be the optimum design for trouble-free supply of non-linear loads. The 2/3 pitch design avoids excessive neutral currents sometimes seen with higher winding pitches, when in parallel with the mains. A fully connected damper winding reduces oscillations during paralleling. This winding, with the 2/3 pitch and carefully selected pole and tooth designs, ensures very low waveform distortion.

SX460 AVR

With this self excited control system the main stator supplies power via the Automatic Voltage Regulator (AVR) to the exciter stator. The high efficiency semiconductors of the AVR ensure positive build-up from initial low levels of residual voltage.

This exciter rotor output is fed to the main rotor through a three phase full wave bridge rectifier. This rectifier is protected by a surge suppressor against surges caused, for example, by short circuit.

Terminals&Terminal Box

Standard generators are 3-phase reconnectable with 12 ends brought out to the terminals, which are mounted on a cover at the non-drive end of the generator. A sheet steel terminal box contains the AVR and provides ample space for the customer's wiring and gland arrangements. It has removable panels for easy access.

Shaft&Keys

All generator rotors are dynamically balanced to better than BS6861:Part 1 Grade 2.5 for minimum vibration in operation. Two bearing generators are balanced with a half key.

Insulation / Impregnation

The insulation system is class 'H'

All wound components are impregnated with materials and processes designed specifically to provide the high build required for static windings and the high mechanical strength required for rotating components.

Standards

Newage Stamford industrial generators meet the requirements of **BS EN 60034** and the relevant section of other international standards such as **BS5000, VDE0530, NEMA MG1-32, IEC34, CSA C22.2-100, AS1359**. Other standards and certifications can be considered on request.

Quality Assurance

Generators are manufactured using production procedures having a quality assurance level to BS EN ISO 9001.

| Model | Standby | | Prime | |
|----------------|------------|------------|------------|------------|
| | kVA | kW | kVA | kW |
| UCI274E | 150 | 120 | 140 | 112 |

Technical Specifications

| | |
|--|--|
| Manufacturer | NEWAGE / STAMFORD |
| Model | UCI274E |
| Type | 4-Poles, Rotating Field, Brushless |
| Standby power at rated voltage, kVA | 150 |
| Efficiency, % | %91.4 |
| Power factor | 0.8 |
| Phase | 3 |
| Frequency, Hz | 50 |
| Speed, Rpm | 1500 |
| Voltage, V | 380/415 |
| Excitation | Self excited |
| Stator windings | 2/3 Pitch factor |
| Regulation | AVR, Automatic Voltage Regulator |
| Voltage Regulator | SX460 |
| Voltage Regulation, % | ± 1.5 |
| R.F.I Suppression | BS EN 61000-6-2 & BS EN 61000-6-4 VDE0875G, VDE 0875N |
| Waveform distortion | No Load <1.5% Non distorting balanced linear load <5.0% |
| Rotor | Dynamic balanced |
| Overspeed, Rpm | 2250 |
| Short circuit current | < 300% |
| TIF | Less than 50 |
| Insulation class | H |
| Construction | Single bearing, direct coupled |
| Coupling | Flexible |
| Stator winding | Double layer concentric |
| Connection | WYE |
| Protection class | IP23 |
| Cooling air volume, m ³ / sec | 0.514 |

Optional Equipment

- ◊Optional Permanent Magnet Generator (PMG) provides an isolated power supply to the excitation control system
- ◊Anti Condensation Heaters
- ◊Air Filters
- ◊Temperature Indication RTD's
- ◊Winding Protection Thermistors
- ◊Quadrature Droop kit for Parallel Operation
- ◊SX440 AVR with 1% Regulation and 2 Phase Sensing
- ◊SX421 AVR with 3 Phase Sensing and improved Regulation 0.5%
- ◊MX341 (PMG) 1% Regulation with 2 Phase Sensing
- ◊MX321 (PMG) with 3 Phase Sensing and improved Regulation 0.5%

Control Panel

Standard Equipments

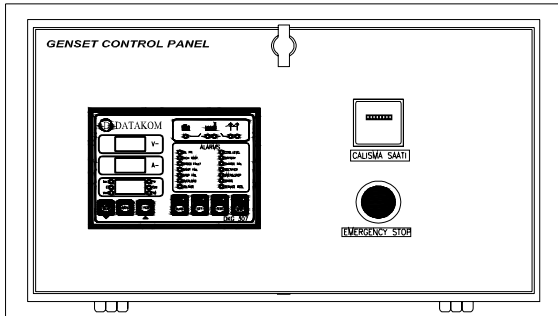

- ◊Datakom DKG307 digital automatic control module
- ◊Hourmeter
- ◊Emergency stop button

Datakom DKG307 Control Module

Description

- ◊The DKG-307 is a comprehensive AMF unit for a single generating set operating in standby mode.
- ◊In AUTOMATIC position, DKG-307 monitors mains phase voltages and controls the automatic starting, stopping and load transfer of the generating set in case of a mains failure and once the generator is running, it monitors internal protections and external fault inputs. If a fault condition occurs, the unit shuts down the engine automatically and indicates the failure source with the corresponding red led lamp.
- ◊The DKG-307 provides a comprehensive set of digitally adjustable timers, threshold levels, input and output configurations and operating sequences. The unauthorized access to program parameters is prevented by the program lock input. All programs may be modified via front panel pushbuttons, and do not require an external unit.
- ◊The fault conditions are considered in 2 categories as Warnings and Alarms. Measured values have separate programmable limits for warning and alarm conditions.
- ◊The service request indicator lamp turns on at the expiration of either engine hours or time limits.
- ◊It is possible to monitor the operation of the system locally or remotely with the WINDOWS based PC utility program.
- ◊The unit is designed for front panel mounting. It is fitted into the cut-out with the steel spring removed. Connections are made with 2 part plug and socket connectors.

Pushbutton Controls

STOP / START
 AUTO, TEST, MANUAL
 LCD PAGE

Features

- Automatic mains failure with genset control and protection
- Remote Start operation capability
- Analogue temperature and oil pressure inputs
- Genset KW and Power Factor measurement
- Engine hours run counter
- Periodic maintenance request display
- 165 programmable parameters
- Battery backed-up real time clock
- Weekly operation schedule programs
- Daily, weekly, monthly exerciser
- Event logging with time stamp
- Statistical counters
- Serial RS-232 data output for telemetry on PC
- Free MS-Windows remote monitoring SW
- Configurable analogue inputs: 2
- Configurable digital inputs: 7
- Configurable relay outputs: 2
- Output expansion capability
- Small dimensions (155x115x48mm)

Input Functions display on LCD

| | |
|------------------------|---------------------------|
| Generator Volts | Volts L1-N, L2-N, L3-N |
| Generator Volts | Volts L1-L2, L2-L3, L3-L1 |
| Generator Amps | Amps L1, L2, L3 |
| Generator Frequency | Hz |
| Mains Volts | Volts L1-N, L2-N, L3-N |
| Mains Volts | Volts L1-L2, L2-L3, L3-L1 |
| Mains Frequency | Hz |
| Engine Speed | RPM |
| Plant Battery Volts | Volts |
| Engine Hours Run | Hour |
| Generator total power | kVA L1, L2, L3,total |
| Generator total power | kW L1, L2, L3,total |
| Generator power factor | Cosφ L1, L2, L3,total |

Optional Input Functions

| | |
|---------------------|-----|
| Engine Oil pressure | kPa |
| Fuel level | % |
| Engine Temperature | °C |

Alarm Channels

- Under/over generator voltage
- Over-current
- Under/over generator frequency
- Under/over speed
- Charge fail
- Emergency stop
- Low oil pressure
- High engine temperature
- Fail to start
- Low/high DC battery voltage
- Reverse power
- Generator phase rotation error
- Generator short-circuit protection
- Loss of speed sensing signal
- Mains out of limits

Model Codes and General Information

Cukurova Diesel Generator

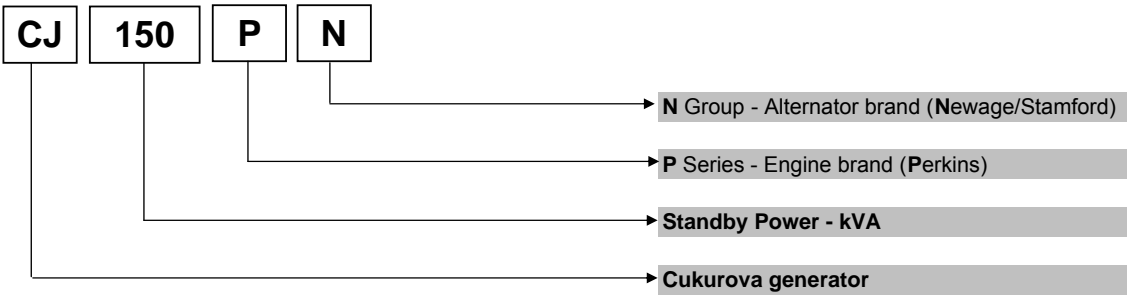

Perkins 1000 Series Diesel Engine

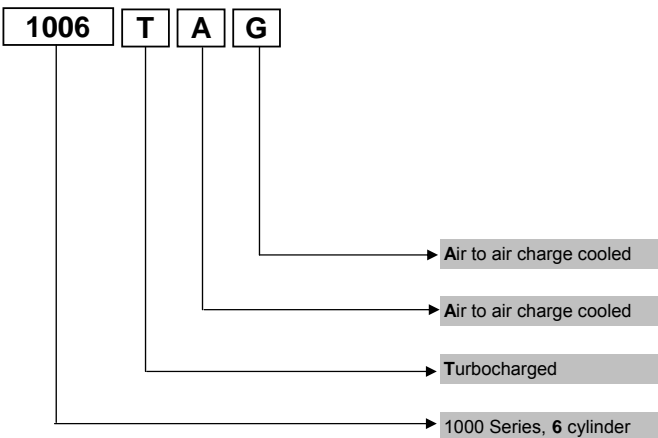

Newage / Stamford Alternator

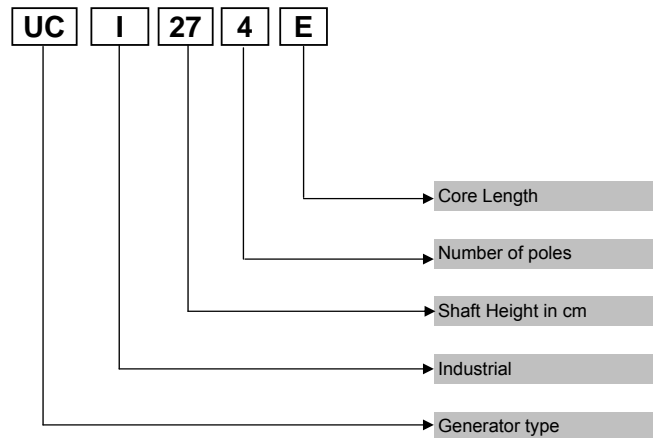

Information

Power Ratings

Standby power rating is for the supply of emergency power at variable load for the duration of the non-availability of the mains power supply. No overload capacity is available at this rating. A standby rated engine should be sized for an average load factor of 80% based on published standby rating for 500 operating hours per year. Standby ratings should never be applied except in true emergency power failure conditions.

Prime power rating is available for unlimited hours per year with a variable load of which the average engine load factor is 80% of the published power rating, incorporation of a 10% overload for 1 hour in every 12 hours of operation which permitted

Continuous power rating is available for continuous full load operation. No overload is permitted.

Acc. to ISO 3046/1, BS 5514, DIN6271

Electric Formulas

| Values | Formula | |
|-----------|--|---------------------------------------|
| kWe | kWm X E | |
| kWe | $(U \times I \times 1.73 \times pf) / 1000$ | kVA x pf |
| kVA | $(U \times I \times 1.73) / 1000$ | kWe / pf |
| I (Amp) | $(kWe \times 1000) / (U \times 1.73 \times pf)$ | $(kVA \times 1000) / (U \times 1.73)$ |
| Frequency | $(Rpm \times N^{\circ}Pole) / (2 \times 60)$ | |
| Rpm | $(2 \times 60 \times Frequency) / N^{\circ}Pole$ | |

- kWm: Mechanical Power
- kWe : Electrical Power
- pf : Power factor
- E : Alternator efficiency
- I : Current (A)
- U : Voltage (V)
- kVA : Power
- Rpm: Revolutions per minute

General Dimensions

Standard Generator

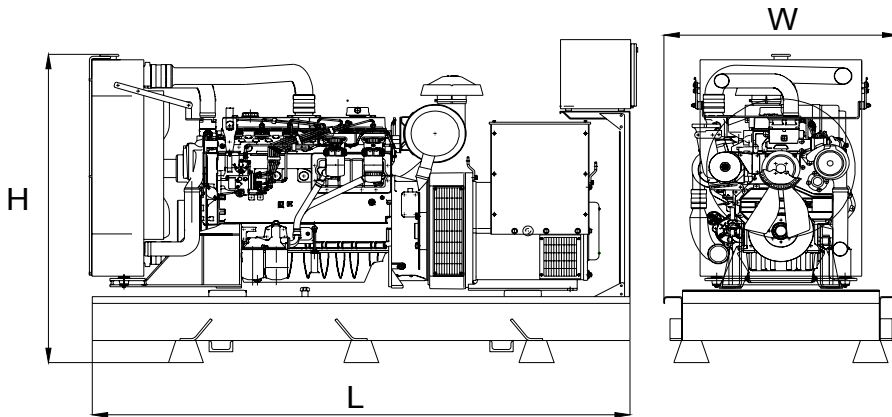

| | |
|----------------------|---------|
| Length, L | 2,3 m |
| Height, H | 1,5 m |
| Width, W | 1 m |
| Weight, Total | 1350 kg |

Generator with Soundproof Canopy

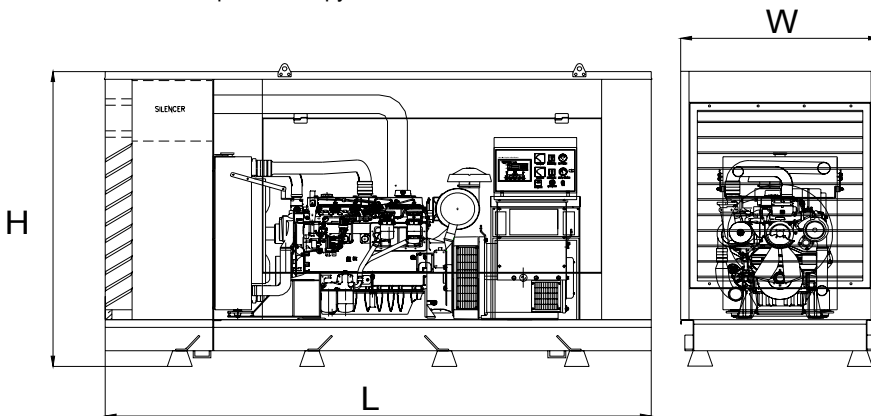

| | |
|----------------------|---------|
| Length, L | 3,3 m |
| Height, H | 2 m |
| Width, W | 1,2 m |
| Weight, Total | 1850 kg |

Generator Room Layout

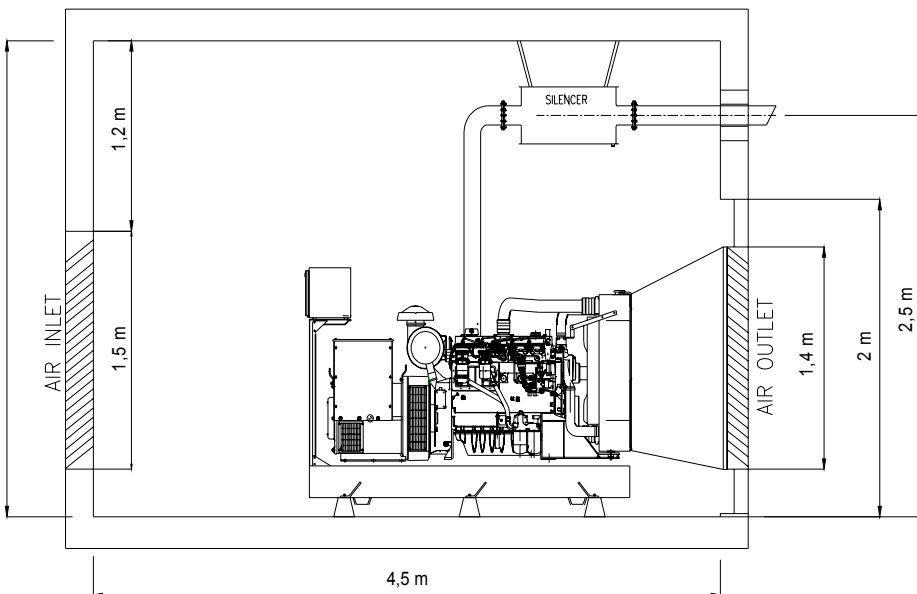

Above drawings dimensions and weights are only for guidance. For installation design of your specific application, necessary certified drawings, at site consultancy service as well as maintenance and installations manuals will be provided by Cukurova without any charge.

Specifications may change without notice

| | | |
|--|--|---|
| | <p>CUKUROVA JENERATOR SANAYII TICARET A.S.</p> <p><u>Izmir Factory</u> Aegean Free Zone, Boss Sokak No:11, Gaziemir - Izmir, Turkey Tel : +90 232 252 2026 Fax : +90 232 252 2027</p> | <p><u>Istanbul Export Sales Office</u> Ankara Yolu, Tuzla Tersane Kavşagi No:26 34947 Tuzla-Istanbul, Turkey Tel : +90 216 395 3460 Fax : +90 216 395 5453 Mail : info@cukurovapower.com</p> |
| | <p><small>All information in this document is substantially correct at time of printing and may be altered subsequently.</small></p> | |