

CUKUROVA GENERATOR SYSTEMS

1500 Rpm, 50Hz, 400V

Volvo TAD732GE diesel engine

Leroy Somer LSA 46.2 M3 alternator

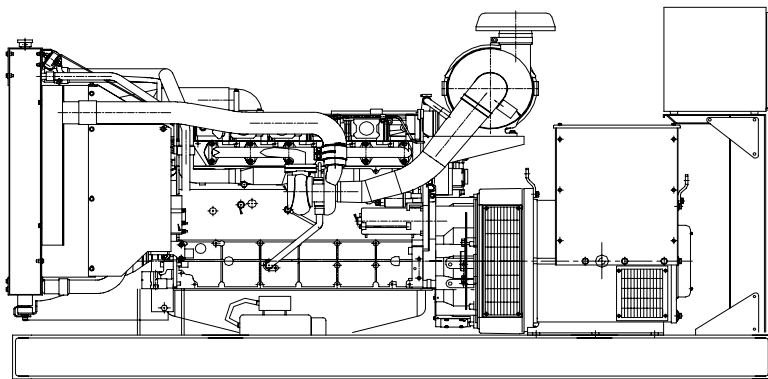

Standard Generator Features

- ◊ AMF, Automatic mains failure unit
- ◊ Heavy duty type, 6 cylinder, water cooled engine
- ◊ 55°C tropical type radiator
- ◊ Starter motor
- ◊ Lead acid battery
- ◊ Charging alternator
- ◊ Battery charge redressor
- ◊ Heavy duty, brushless type alternator
- ◊ Base frame with anti-vibration units
- ◊ Industrial type silencers
- ◊ Flexible exhaust compensator
- ◊ Block water heater unit
- ◊ Control panel with digital-automatic main control module
- ◊ Fan, fan drive, charging alternator drive and all rotating parts covered
- ◊ Radiator matrix covered by metal mesh against the mechanical damages
- ◊ Fabricated and welded steel base frame
- ◊ Anti-vibration mountings
- ◊ Engine and alternator manufacturer test reports
- ◊ Factory load, performance and function tests

Optional Features

- ◊ Automatic load transfer panel
- ◊ Automatic synchronization and power sharing systems
- ◊ Soundproof canopy
- ◊ Container type enclosures
- ◊ Road trailer
- ◊ Job-site trailer
- ◊ Protection circuit breaker
- ◊ Air start
- ◊ Remote type radiator
- ◊ Base fuel tank
- ◊ External type fuel tank
- ◊ Automatic fuel transfer system
- ◊ Residential silencer



Model	Standby		Prime	
	kVA	kW	kVA	kW
CJ200VL	201	160	181	144

APPLICATION DATA

Volvo TAD732GE Engine

Standard Features

The TAD732GE is a powerful, reliable and economical Generating Set Diesel built on the dependable in-line six design.

Low exhaust emission

The state of the art, high-tech injection and charging system with low internal losses contributes to excellent combustion and low fuel consumption.

The TAD732GE complies with EU Stage 2 and, TA-Luft exhaust emission regulations.

Easy service & maintenance

Easily accessible service and maintenance points contribute to the ease of service of the engine.

Engine and Block

- ◊In-line 6-cylinder
- ◊Piston cooling for low piston temperature and reduce ring temperature
- ◊Drop forged steel connecting rods
- ◊Keystone top compression rings for long service life
- ◊Replaceable valve guides and valve seats
- ◊Three PTO positions at flywheel
- ◊Lift eyelets
- ◊Flywheel housing with connection acc.to SAE2
- ◊Flywheel for flexible coupling and striction clutch
- ◊Transport brackets

Technical Specifications

Manufacturer	VOLVO
Model	TAD732GE
Type	4 cycle, water-cooled, diesel engine
Number of cylinders	6
Cylinder arrangement	Vertical in-line
Displacement, Liters	7.15
Bore X Stroke, mm	108 X 130
Compression Ratio	18:01
Combustion System	Direct injection
Aspiration	Turbocharged, air-to-air charge cooled
Rotation	Anti-clockwise viewed on flywheel
Gross engine power, kWb	183
Fan Power, kWm	7
BMEP gross, Mpa	2,1
Exhaust gas temp.(after turbo), °C	542
Exhaust gas flow (after turbo),m³ / min	35,1
Mean piston speed, m / s	6.5

Model	Standby kW		Prime kW	
	Gross	Net	Gross	Net
TAD732GE	183	176	165	158

Cooling System

Type	Tropical, heavy duty type
Ambient temperature, °C	55
Engine+Radiator coolant cap., Liters	38
Jacket coolant flow, Liters / sec	3.0

- ◊Tropical radiator incl intercooler
- ◊Gear driven coolant pump
- ◊Fan hub

Electrical System

Alternator	1x55A/24V,low left
Starter motor (DC)	Melco, 24V
Starter motor power	5,0kW

Fuel System

Type of injection system	Direct injection
Fuel injector	Electronic unit injector
Delivery/hour at 1500rev/min, Liters	360
Governor type	Heinzmann / EDC4
◊Six hole fuel injection nozzles	
◊Direct injection unit pumps	

Fuel Consumption

liters per hour	%100 Load	214 L
	%75 Load	212 L
	%50 Load	215 L
	%25 Load	234 L

Lubricating System

Type	Pressurized
Capacity, Liters	34
Lub oil pressure ,kPa	480
◊Rotary type lubrication oil pump driven by crankshaft	
◊Full flow disposable spin-on oil filter, for extra high filtration	
◊Deep centre oil sump driven by the crankshaft	
◊Oil filter on top	

Leroy Somer LSA 46.2 M3 Alternator

Standard Features

Top of the Range Electrical Performance

Class H insulation
 Standard 12-wire re-connectable winding, 2/3 pitch
 High efficiency and motor starting capacity
 R 791 interference suppression conforming to standard EN 55011 group 1
 class B standard for European zone (CE marking)

Protection System Suited to the Environment

The LSA 46.2 is IP21

Reinforced Mechanical Structure Using Finite Element Modelling

Compact and rigid assembly to better withstand generator-set vibrations
 Steel frame
 Cast iron flanges and shields
 Twin-bearing and single bearing versions designed to be suitable for engines on the market
 Half-key balancing
 Greased for life bearings (regreasable bearings optional)

Accessible Terminal Box Proportioned for Optional Equipment

Easy access to the voltage regulator and to the connections
 Possible inclusion of accessories for paralleling, protection and measurement
 8 way terminal block for reconnecting voltage reconnection

Compliant with International Standards

The LSA 46.2 alternator conforms to the main international standards and regulations:

IEC 60034, NEMA MG 1.22, ISO 8528, CSA, CSA/UL

It can be integrated into a CE marked generator set
 The LSA 46.2 is designed, manufactured and marketed in an ISO 9001 environment

Model	Standby		Prime	
	kVA	kW	kVA	kW
LSA 46.2 M3	203	162	180	144

Technical Specifications

Manufacturer	LEROY SOMER
Model	LSA 46.2 M3
Type	4-Poles, Rotating Field, Brushless
Standby power at rated voltage, kVA	203
Efficiency, %	91,3
Power factor	0.8
Phase	3
Frequency, Hz	50
Speed, Rpm	1500
Voltage, V	400
Excitation	AREP or PMG
Stator windings	2/3 Pitch factor
Regulation	AVR, Automatic Voltage Regulator
Voltage Regulator	R 448
Voltage Regulation, %	± 0.5
Total HarmonicTGH / THC	at no load<1.5% - on load<2%
Waveform: NEMA = TIF	< 50
Waveform: I.E.C = THF,	< 2%
Insultion class	H
Overspeed, Rpm	2250
Construction	Single bearing, direct coupled
Coupling	Flexible
Amortisseur Windings	Full
Connection	WYE
Rotor	Dynamic balanced
Protection class	IP21
Air flow, m ³ / min	0,43

Optional Equipment

- ◊Filters on air inlet and air outlet (IP44)
- ◊Windign protection for clean environmetns with relative humidity greater than 95%
- ◊Space heaters
- ◊Thermal protection for winding
- ◊Digital voltage regulator
- ◊PMG system

Control Panel

Standard Equipments

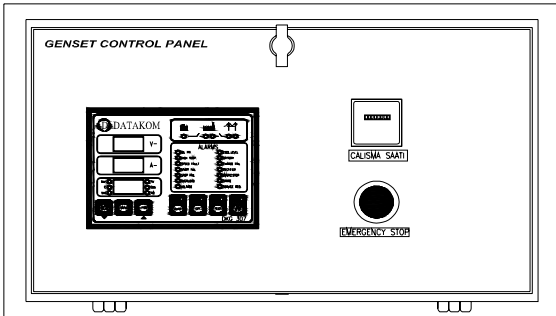

- ◊Datakom DKG307 digital automatic control module
- ◊Hourmeter
- ◊Emergency stop button

Datakom DKG307 Control Module

Description

- ◊The DKG-307 is a comprehensive AMF unit for a single generating set operating in standby mode.
- ◊In AUTOMATIC position, DKG-307 monitors mains phase voltages and controls the automatic starting, stopping and load transfer of the generating set in case of a mains failure and once the generator is running, it monitors internal protections and external fault inputs. If a fault condition occurs, the unit shuts down the engine automatically and indicates the failure source with the corresponding red led lamp.
- ◊The DKG-307 provides a comprehensive set of digitally adjustable timers, threshold levels, input and output configurations and operating sequences. The unauthorized access to program parameters is prevented by the program lock input. All programs may be modified via front panel pushbuttons, and do not require an external unit.
- ◊The fault conditions are considered in 2 categories as Warnings and Alarms. Measured values have separate programmable limits for warning and alarm conditions.
- ◊The service request indicator lamp turns on at the expiration of either engine hours or time limits.
- ◊It is possible to monitor the operation of the system locally or remotely with the WINDOWS based PC utility program.
- ◊The unit is designed for front panel mounting. It is fitted into the cut-out with the steel spring removed. Connections are made with 2 part plug and socket connectors.

Pushbutton Controls

STOP / START
 AUTO, TEST, MANUAL
 LCD PAGE

Features

- Automatic mains failure with genset control and protection
- Remote Start operation capability
- Analogue temperature and oil pressure inputs
- Genset KW and Power Factor measurement
- Engine hours run counter
- Periodic maintenance request display
- 165 programmable parameters
- Battery backed-up real time clock
- Weekly operation schedule programs
- Daily, weekly, monthly exerciser
- Event logging with time stamp
- Statistical counters
- Serial RS-232 data output for telemetry on PC
- Free MS-Windows remote monitoring SW
- Configurable analogue inputs: 2
- Configurable digital inputs: 7
- Configurable relay outputs: 2
- Output expansion capability
- Small dimensions (155x115x48mm)

Input Functions display on LCD

Generator Volts	Volts L1-N, L2-N, L3-N
Generator Volts	Volts L1-L2, L2-L3, L3-L1
Generator Amps	Amps L1, L2, L3
Generator Frequency	Hz
Mains Volts	Volts L1-N, L2-N, L3-N
Mains Volts	Volts L1-L2, L2-L3, L3-L1
Mains Frequency	Hz
Engine Speed	RPM
Plant Battery Volts	Volts
Engine Hours Run	Hour
Generator total power	kVA L1, L2, L3, total
Generator total power	kW L1, L2, L3, total
Generator power factor	Cosφ L1, L2, L3, total

Optional Input Functions

Engine Oil pressure	kPa
Fuel level	%
Engine Temperature	°C

Alarm Channels

- Under/over generator voltage
- Over-current
- Under/over generator frequency
- Under/over speed
- Charge fail
- Emergency stop
- Low oil pressure
- High engine temperature
- Fail to start
- Low/high DC battery voltage
- Reverse power
- Generator phase rotation error
- Generator short-circuit protection
- Loss of speed sensing signal
- Mains out of limits

Model Codes and General Information

Cukurova Diesel Generator

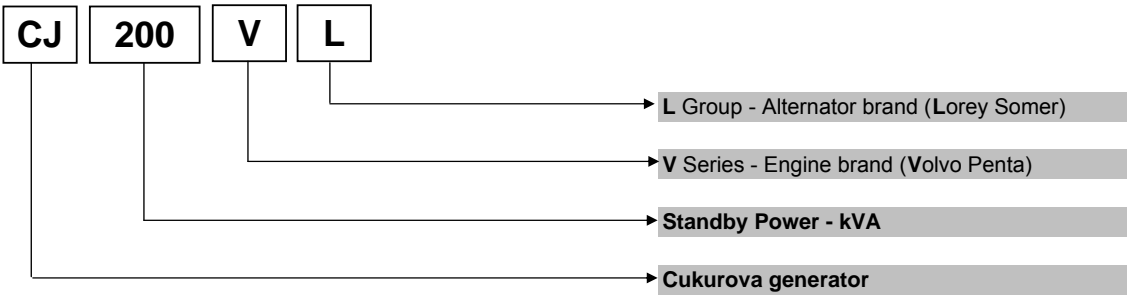

Volvo Penta Diesel Engine

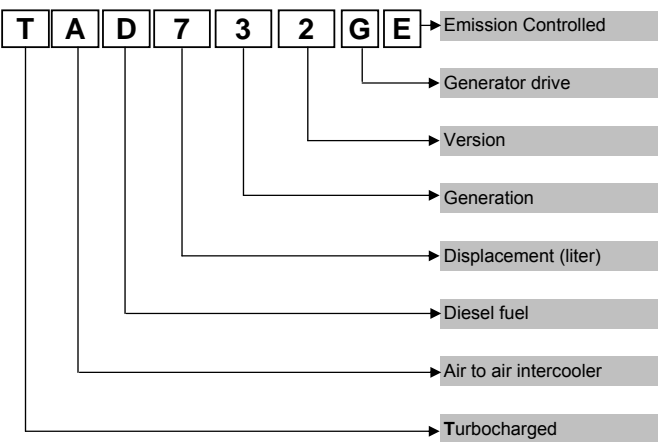

Leroy Somer Alternator

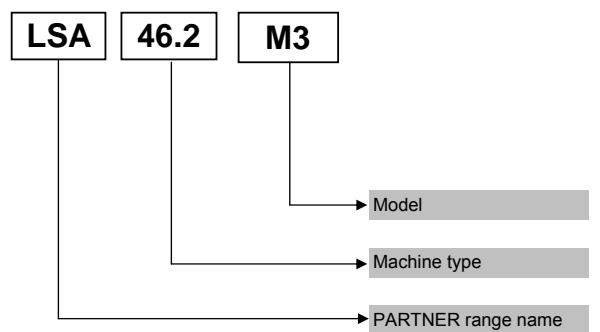

Information

Power Ratings

Standby power rating is for the supply of emergency power at variable load for the duration of the non-availability of the mains power supply. No overload capacity is available at this rating. A standby rated engine should be sized for an average load factor of 80% based on published standby rating for 500 operating hours per year. Standby ratings should never be applied except in true emergency power failure conditions.

Prime power rating is available for unlimited hours per year with a variable load of which the average engine load factor is 80% of the published power rating, incorporation of a 10% overload for 1 hour in every 12 hours of operation which permitted

Continuous power rating is available for continuous full load operation. No overload is permitted.

Acc. to ISO 3046/1, BS 5514, DIN6271

Electric Formulas

Values	Formula	
kWe	kWm X E	
kWe	$(U \times I \times 1.73 \times pf) / 1000$	kVA x pf
kVA	$(U \times I \times 1.73) / 1000$	kWe / pf
I (Amp)	$(kWe \times 1000) / (U \times 1.73 \times pf)$	$(kVA \times 1000) / (U \times 1.73)$
Frequency	$(Rpm \times N^{\circ}Pole) / (2 \times 60)$	
Rpm	$(2 \times 60 \times Frequency) / N^{\circ}Pole$	

- kWm**: Mechanical Power
- kWe**: Electrical Power
- pf**: Power factor
- E**: Alternator efficiency
- I**: Current (A)
- U**: Voltage (V)
- kVA**: Power
- Rpm**: Revolutions per minute

General Dimensions

Standard Generator

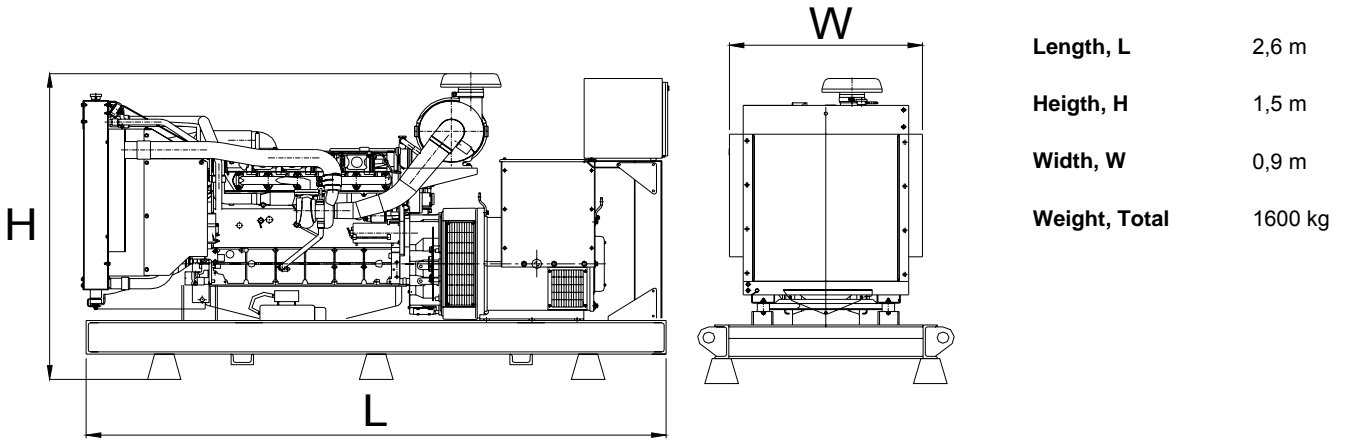

Generator with Soundproof Canopy

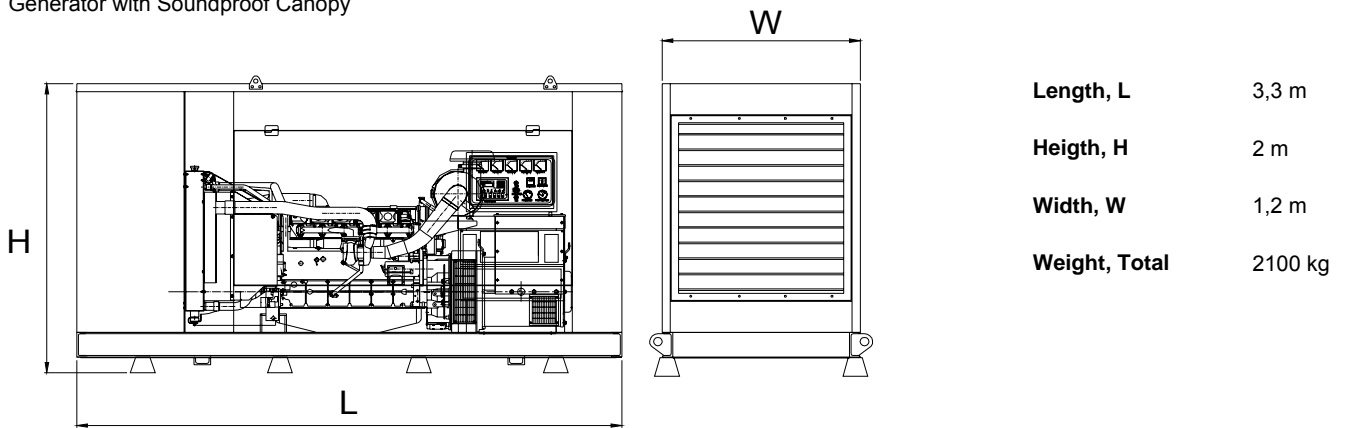

Generator Room Layout

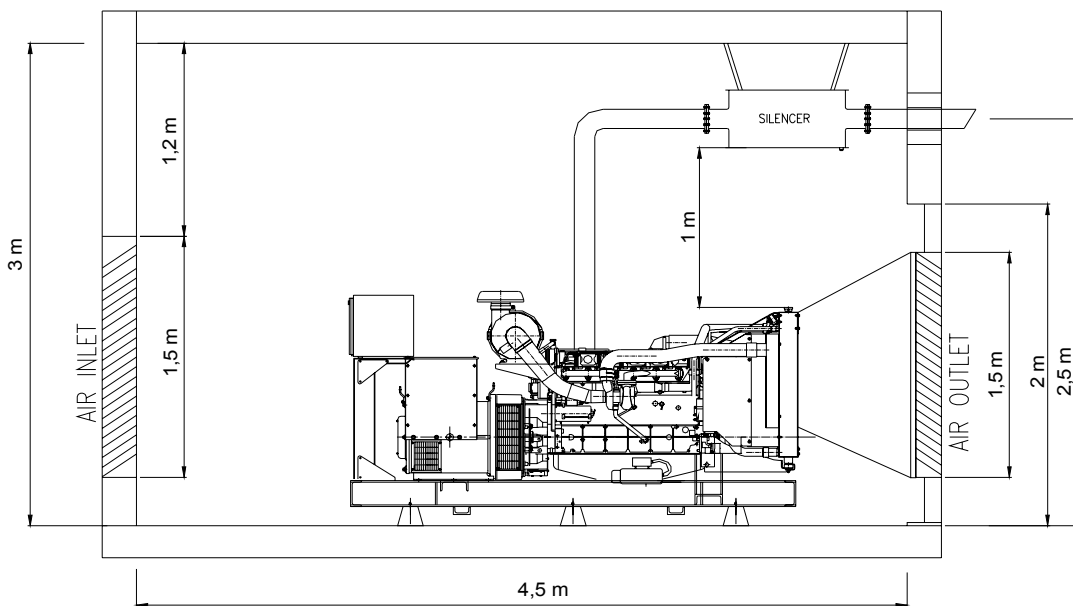

Above drawings dimensions and weights are only for guidance. For installation design of your specific application, necessary certified drawings, at site consultancy service as well as maintenance and installations manuals will be provided by Cukurova without any charge.

Specifications may change without notice

	CUKUROVA JENERATOR SANAYII TICARET A.S.	
	<table border="0"> <tr> <td> Izmir Factory Aegean Free Zone Boss Sokak No:11, Gaziemir Izmir, Turkey Tel : +90 232 252 20 26 Fax : +90 232 252 20 27 </td> <td> Istanbul Export Sales Office Ebulula Mardin Caddesi Maya Meridyen İş Merkezi Kat:4 No: 14 Akatlar Istanbul, Turkey Tel : +90 212 352 70 90 Fax : +90 212 352 12 77 E-mail : info@cukurovapower.com </td> </tr> </table>	Izmir Factory Aegean Free Zone Boss Sokak No:11, Gaziemir Izmir, Turkey Tel : +90 232 252 20 26 Fax : +90 232 252 20 27
Izmir Factory Aegean Free Zone Boss Sokak No:11, Gaziemir Izmir, Turkey Tel : +90 232 252 20 26 Fax : +90 232 252 20 27	Istanbul Export Sales Office Ebulula Mardin Caddesi Maya Meridyen İş Merkezi Kat:4 No: 14 Akatlar Istanbul, Turkey Tel : +90 212 352 70 90 Fax : +90 212 352 12 77 E-mail : info@cukurovapower.com	