

**CUKUROVA GENERATOR SYSTEMS**

1500 Rpm, 50Hz, 400V

Perkins 4016TAG2A diesel engine

Newage/Stamford PI734F alternator

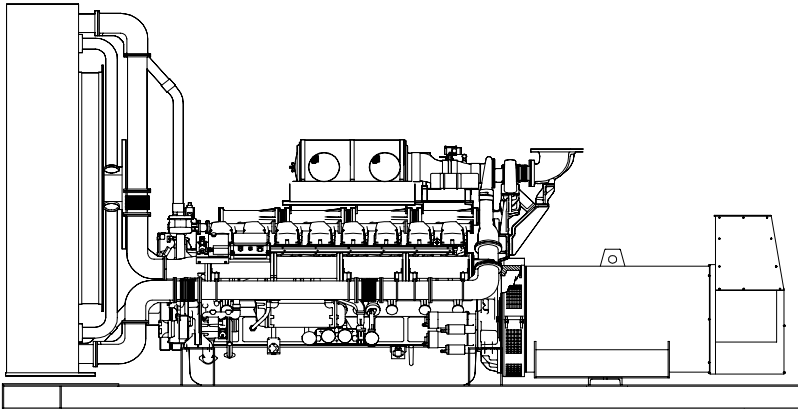

**Standard Generator Features**

- ◊ AMF, Automatic mains failure unit
- ◊ Heavy duty type, 16 cylinder, water cooled engine
- ◊ 52°C tropical type radiator
- ◊ Starter motor
- ◊ Lead acid battery
- ◊ Charging alternator
- ◊ Battery charge redressor
- ◊ Heavy duty, brushless type alternator
- ◊ Base frame with anti-vibration units
- ◊ Industrial type silencers
- ◊ Flexible exhaust compensator
- ◊ Block water heater unit
- ◊ Control panel with digital-automatic main control module
- ◊ Fan, fan drive, charging alternator drive and all rotating parts covered
- ◊ Radiator matrix covered by metal mesh against the mechanical damages
- ◊ Fabricated and welded steel base frame
- ◊ Anti-vibration mountings
- ◊ Engine and alternator manufacturer test reports
- ◊ Factory load, performance and function tests

**Optional Features**

- ◊ Automatic load transfer panel
- ◊ Automatic synchronization and power sharing systems
- ◊ Container type enclosures
- ◊ Road trailer
- ◊ Job-site trailer
- ◊ Protection circuit breaker
- ◊ Air start
- ◊ Remote type radiator
- ◊ External type fuel tank
- ◊ Automatic fuel transfer system
- ◊ Residential silencer



Model	Standby		Prime	
	kVA	kW	kVA	kW
<b>CJ2250PN</b>	<b>2250</b>	<b>1800</b>	<b>2058</b>	<b>1646</b>

**APPLICATION DATA**

**Perkins 4016TAG2A Engine**

**Standard Features**

**Economic power**

- ◊ Individual four valve per cylinder heads give optimised gas flows, while unit fuel injectors ensure ultra fine fuel atomisation and hence controlled rapid combustion, for efficiency and economy
- ◊ Commonality of components with other engines in the 4000 Series family allows reduced parts stocking levels

**Reliable power**

- ◊ Developed and tested using latest engineering techniques
- ◊ Piston temperatures are controlled by an advanced gallery jet cooling sys.
- ◊ All engines are tolerant of a wide range of temperatures without derate
- ◊ Service is provided by the extensive Perkins network of over 4.000 distributors and dealers worldwide

**Clean, efficient power**

- ◊ Exceptional power to weight ratio and compact size for easier transportation and installation
- ◊ Designed to provide excellent service access for easy of maintenance
- ◊ Engines designed to comply with major international standards
- ◊ Low gaseous emissions for cleaner operation

**Standards**

- ◊ UK MOD, BS5750, ISO9001, BS5514/1-1982, ISO 3046/1, ISO 8528/1

**Technical Specifications**

Manufacturer	PERKINS
Model	4016TAG2A
Type	4 cycle, water-cooled, diesel engine
Number of cylinders	16
Cylinder arrangement	60° Vee
Displacement, Liters	61.123
Bore X Stroke, mm	160 X 190
Compression Ratio	13.6:1
Combustion System	Direct injection
Aspiration	Turbocharge, air-to-air charge cooled
Rotation	Anti-clockwise viewed on flywheel
Gross engine power, kWb	1937
Fan Power, kWm	51
BMEP gross, bar	25.4
Combustion air flow, m³ / min	145
Exhaust gas temp.(after turbo), °C	493
Exhaust gas flow (after turbo), m³ / min	387
Mean piston speed, m / s	9,5

**Cooling System**

Type	Tropical, heavy duty type
Ambient temperature, °C	52
Engine coolant capacity, Liters	95
Engine+Radiator coolant cap., Liters	316
Jacket coolant flow, Liters / sec	19
Cooling min airflow, m³ / min	2430
◊ Twin gear driven circulating pumps	
◊ Two twin thermostats	
◊ Crankshaft pulley for fan drive	

Model	Standby kWm		Prime kWm	
	Gross	Net	Gross	Net
<b>4016TAG2A</b>	<b>1937</b>	<b>1886</b>	<b>1766</b>	<b>1715</b>

**Lubricating System**

Type	Pressurized
Capacity, Liters	214
Lub oil temp. Max to bearings, °C	105
Lub oil pressure (at 80°C,min), MPa	0.34
◊ Wet sump with filler and dipstick	
◊ Full flow spin on oil filters	
◊ Engine jacket lub oil temperature stabilizer	

**Fuel System**

Type of injection system	Direct injection
Fuel injection pump	Combined unit injector
Fuel injector opening pressure, bar	234
Delivery/hour at 1500rev/min, Liters	1380
Fuel lift pump	Tuthill TCH 5
Governor type	Electronic governor to ISO 3046 Part 4 class A1
◊ Unit fuel injectors with lift pump and hand stop control	
◊ Full flow spin-on fuel filters	

**Electrical System**

Alternator	24 Volt with integral regulator
Starter motor (DC)	24 Volt
Starter motor power	16.4 kW
◊ Combined high coolant temperature / low oil pressure switch	
◊ Overspeed switch and magnetic pick up	
◊ Turbo inlet temperature shutdown switch	
◊ 24 Volt stop solenoid	

**Fuel Consumption**

liters per hour	%110 Load	483 L
	%100 Load	434 L
	%75 Load	316 L
	%50 Load	210 L
grams per kWh	%110 Load	212 g/kWh
	%100 Load	209 g/kWh
	%75 Load	203 g/kWh
	%50 Load	202 g/kWh

**Optional Equipments**

- ◊ Twin heavy duty air cleaner - paper element with pre-cleaner
- ◊ Changeover lubricating oil filter
- ◊ Changeover fuel oil filter
- ◊ Immersion heater with thermostat
- ◊ Air starters

## Newage/Stamford PI734F Alternator

### Standard Features

#### Winding&Electrical Performance

All generator stators are wound to 2/3 pitch. This eliminates triplen (3rd, 9th, 15th...) harmonics on the voltage waveform and is found to be the optimum design for trouble-free supply of non-linear loads. The 2/3 pitch design avoids excessive neutral currents sometimes seen with higher winding pitches, when in parallel with the mains. A fully connected damper winding reduces oscillations during paralleling. This winding, with the 2/3 pitch and carefully selected pole and tooth designs, ensures very low waveform distortion.

#### MX341 AVR

The PI range generators, complete with a PMG, are available with one of two AVRs. Each AVR has soft start voltage build up and built in protection against sustained over-excitation, which will de-excite the generator after a minimum of 8 seconds.

Underspeed protection (UFRO) is also provided on both AVRs. The UFRO will reduce the generator output voltage proportional to the speed of the generator below a presettable level.

The MX341 AVR is two phase sensed with a voltage regulation of  $\pm 1\%$ .

The MX321 AVR is 3 phase rms sensed with a voltage regulation of 0.5%rms

The UFRO circuit has adjustable slope and dwell for controlled recovery from step loads. An over voltage protection circuit will shutdown the output device of the AVR, it can also trip an optional excitation circuit breaker if required.

As an option, short circuit current limiting is available with the addition of current transformers.

Both the MX341 and the MX321 need a generator mounted current transformer to provide quadrature droop characteristics for load sharing during parallel operation.

#### Terminals&Terminal Box

Standard generators feature a main stator with 6 ends brought out to the terminals, which are mounted on the frame at the non-drive end of the generator. A sheet steel terminal box contains the AVR and provides ample space for the customers' wiring and gland arrangements. It has removable panels for easy access.

#### Shaft&Keys

All generator rotors are dynamically balanced to better than BS6861:Part 1 Grade 2.5 for minimum vibration in operation. Two bearing generators are balanced with a half key.

#### Insulation / Impregnation

The insulation system is class 'H', and meets the requirements of UL1446.

All wound components are impregnated with materials and processes designed specifically to provide the high build required for static windings and the high mechanical strength required for rotating components.

#### Standards

Newage Stamford industrial generators meet the requirements of **BS EN 60034** and the relevant section of other international standards such as **BS5000, VDE0530, NEMA MG1-32, IEC34, CSA C22.2-100, AS1359**

Other standards and certifications can be considered on request

#### Quality Assurance

Generators are manufactured using production procedures having a quality assurance level to BS EN ISO 9001.

Model	Standby		Prime	
	kVA	kW	kVA	kW
<b>PI734F</b>	<b>2250</b>	<b>1800</b>	<b>2080</b>	<b>1664</b>

### Technical Specifications

Manufacturer	Newage/Stamford
Model	PI734F
Type	4-Poles, Rotating Field, Brushless
Standby power at rated voltage, kVA	2250
Efficiency, %	95.8
Power factor	0.8
Phase	3
Frequency, Hz	50
Speed, Rpm	1500
Voltage, V	380/415
Excitation	Self excited
Stator windings	2/3 Pitch factor
Regulation	AVR, Automatic Voltage Regulator
Voltage Regulator	MX341
Voltage Regulation, %	$\pm 1$
R.F.I Suppression	BS EN 61000-6-2 & BS EN 61000-6-4 VDE0875G, VDE 0875N
Waveform distortion	No Load <1.5% Non distorting balanced linear load <5.0%
Rotor	Dynamic balanced
Overspeed, Rpm	2250
Short circuit current	< 300%
TIF	Less than 50
Insulation class	H
Construction	Single bearing, direct coupled
Coupling	Flexible
Stator winding	Double layer concentric
Connection	WYE
Protection class	IP23
Cooling air volume, m <sup>3</sup> / sec	2.69

### Optional Equipment

- ◊Winding and bearings RTDs
- ◊Excitation Loss Module
- ◊Anti Condensation Heaters
- ◊Air Filters
- ◊Re-greasable bearings
- ◊Winding Protection Thermistors
- ◊Quadrature Droop kit for Parallel Operation
- ◊Power Factor Controller
- ◊Diode Failure Unit
- ◊Manual Voltage Regulator
- ◊MX321 AVR with 0.5% Regulation and 3 phase sensing

## Standard Equipments

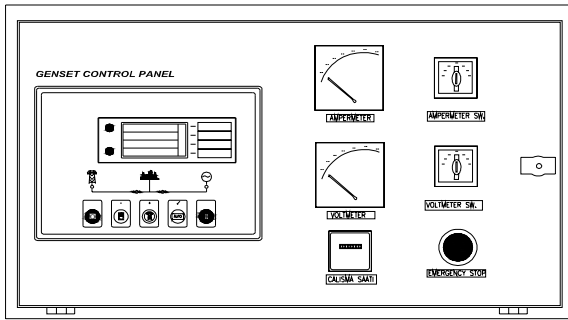

- ◊Deeapse 5220 digital automatic control module
- ◊Hourmeter
- ◊Voltmeter
- ◊Voltmeter commutator
- ◊Ampmeter
- ◊Ampmeter commutator
- ◊Emergency stop button

## Deepsea 5220 Control Module

### Description

- ◊The model 5220 is an Automatic Mains Failure Control module.
- ◊The modul is used to monitor a mains supply and automatically start a standby generator set.
- ◊The module also provides indication of operational status and fault conditions automatically shutting down the genset and indicating failures by means of an LCD display, and appropriate flashing LED on the front panel.
- ◊Selected timers and alarms can be altered by the user from the front panel.
- ◊Alterations to the system are made using the 810 interface and a PC. This interface also provides real time diagnostic facilities

### Specifications

- ◊240mm x 172mm dimensions
- ◊70mm x 40mm dimensions, 4 segment grafical LCD monitor
- ◊Developed 16-bit Microprocessor design
- ◊Easy comprehended display (Hid-Til-Lit SMD LED technology)
- ◊LED mimic diagram
- ◊SMS messaging capability with suitable GSM Modem
- ◊PC software is MS Windows based and allows the operator to control the module from a remote location (P810 Software Kit necessary)
- ◊Easy pushbutton controls
- ◊System parameters can be adjusted manually from the front panel
- ◊kVA,kW ve Cosφ measurements
- ◊Communication with MODEM

### Pushbutton Controls

STOP / START  
 AUTO, TEST, MANUAL  
 LCD PAGE

## Input Functions display on LCD

Generator Volts	Volts L1-N, L2-N, L3-N
Generator Volts	Volts L1-L2, L2-L3, L3-L1
Generator Amps	Amps L1, L2, L3
Generator Frequency	Hz
Mains Volts	Volts L1-N, L2-N, L3-N
Mains Volts	Volts L1-L2, L2-L3, L3-L1
Mains Frequency	Hz
Engine Speed	RPM
Plant Battery Volts	Volts
Engine Hours Run	Hour
Generator total power	kVA L1, L2, L3,total
Generator total power	kW L1, L2, L3,total
Generator power factor	Cosφ L1, L2, L3,total

### Optional Input Functions

Engine Oil pressure	kPa
Fuel level	%
Engine Temperature	°C

### Alarm Channels

- Under/over generator voltage
- Over-current
- Under/over generator frequency
- Under/over speed
- Charge fail
- Emergency stop
- Low oil pressure
- High engine temperature
- Fail to start
- Low/high DC battery voltage
- Reverse power
- Generator phase rotation error
- Generator short-circuit protection
- Loss of speed sensing signal
- Mains out of limits

### Environmental Testing Standards

#### Electromagnetic Compatibility

BS EN 50081-2:1992 and EN 61000-6-4:2000 EMC, Emission Standards for the Industrial Environment  
 EN 61000-6-2:1999 EMC, Immunity Standards for the Industrial Environment

#### Vibration

BS EN 60068-2-6 Ten sweeps (up and back down) at 1 octave/minute in each of the three major axes.  
 5Hz to @ +/-7.5mm constant displacement.  
 8Hz to 500Hz 2gn constant acceleration.

#### Temperature

Cold : BS EN 60068-2-1 to -30°C  
 Hot : BS EN 60068-2-2 to 70°C

#### Humidity

BS EN 2011 part 2.1 93% RH @ 40° for 48 hours

#### Shock

BS EN 6068-2-27 Three half sine shocks in each of the three major axes 15gn amplitude.11mS duration.

#### Electrical Safety

BS EN 60950 Low Voltage Dirctive/Safety of information technology equipments, including electrical business equipment

**Model Codes and General Information**

Cukurova Diesel Generator

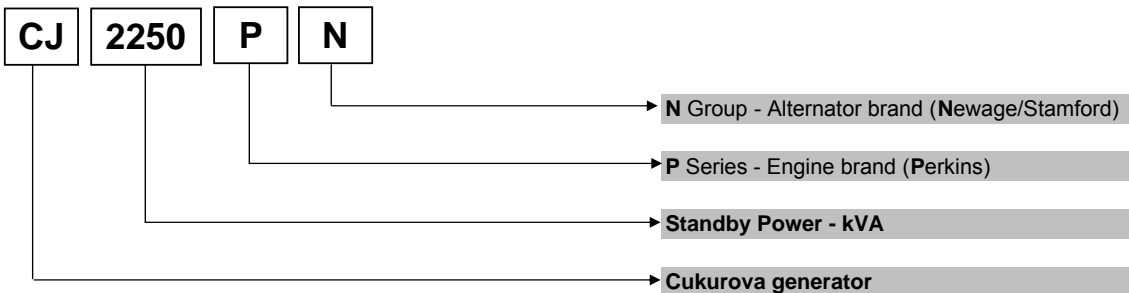

**Perkins 4000 Series Diesel Engine**

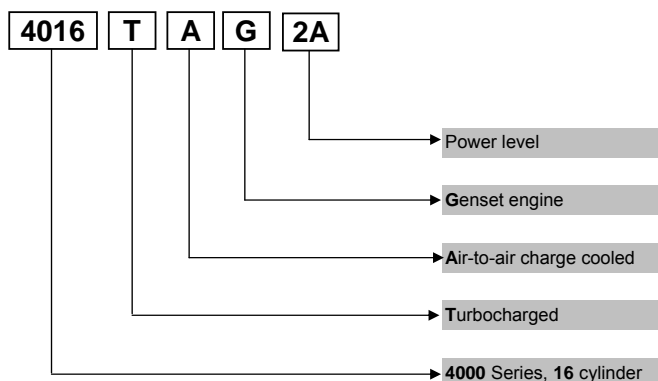

**Newage/Stamford Alternator**

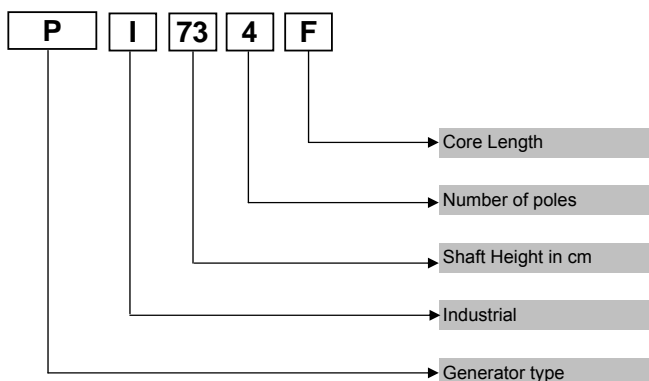

**Information**

**Power Ratings**

**Standby power rating** is for the supply of emergency power at variable load for the duration of the non-availability of the mains power supply.No overload capacity is available at this rating.A standby rated engine should be sized for an average load factor of 80% based on published standby rating for 500 operating hours per year.Standby ratings should never be applied except in true emergency power failure conditions.

**Prime power rating** is available for unlimited hours per year with a variable load of which the average engine load factor is 80% of the published power rating, incorporation of a 10% overload for 1 hour in every 12 hours of operation which permitted

**Continuous power rating** is available for continuous full load operation.No overload is permitted.

Acc. to 3046/1, BS 5514, DIN6271

**Electric Formulas**

Values	Formula	
kWe	kWm X E	
kWe	$(U \times I \times 1.73 \times pf) / 1000$	kVA x pf
kVA	$(U \times I \times 1.73) / 1000$	kWe / pf
I (Amp)	$(kWe \times 1000) / (U \times 1.73 \times pf)$	$(kVA \times 1000) / (U \times 1.73)$
Frequency	$(Rpm \times N^{\circ}Pole) / (2 \times 60)$	
Rpm	$(2 \times 60 \times Frequency) / N^{\circ}Pole$	

- kWm: Mechanical Power
- kWe : Electrical Power
- pf : Power factor
- E : Alternator efficiency
- I : Current (A)
- U : Voltage (V)
- kVA : Power
- Rpm: Revolutions per minute

**General Dimensions**

Standard Generator

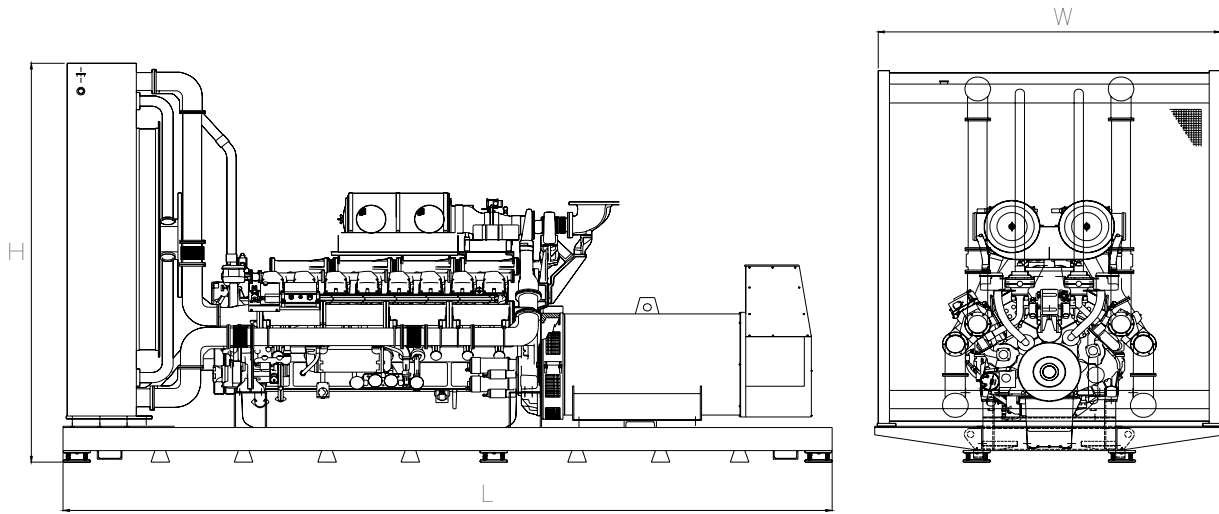

<b>Length, L</b>	5,3 m
<b>Height, H</b>	2,45 m
<b>Width, W</b>	2,3 m
<b>Weight, Total</b>	11.500 kg

**Generator Room Layout**

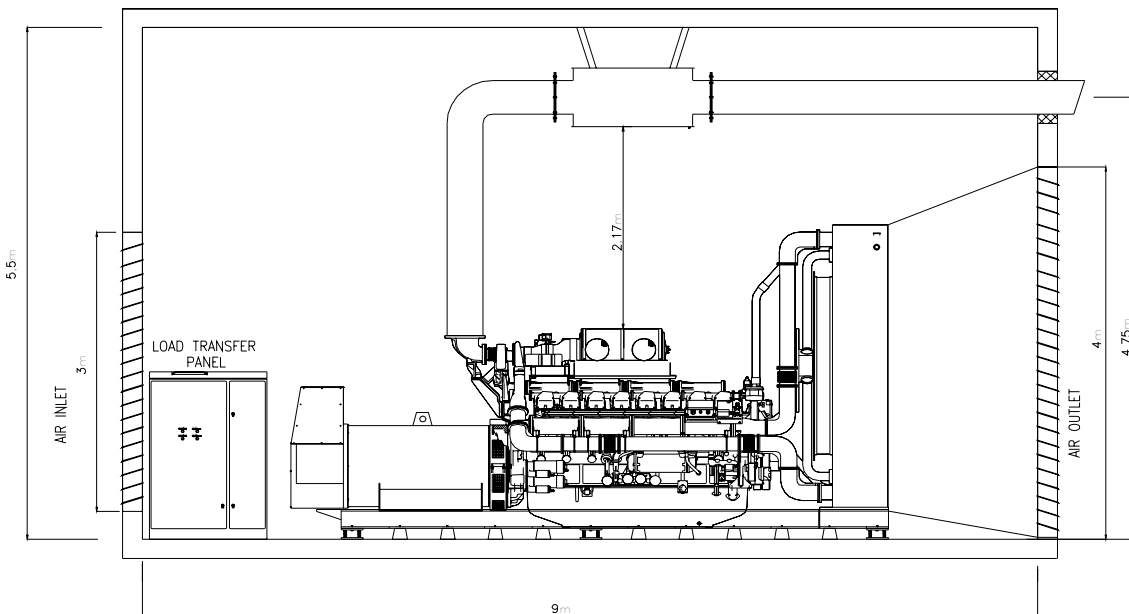

Above drawings dimensions and weights are only for guidance. For installation design of your specific application, necessary certified drawings, at site consultancy service as well as maintenance and installations manuals will be provided by Cukurova without any charge.

Specifications may change without notice

<p style="font-size: 2em; margin: 0;"><b>CUKUROVA</b></p> <p style="font-size: 1.2em; margin: 0;">PowerGeneration</p>	<p><b>CUKUROVA JENERATOR SANAYII TICARET A.S.</b></p>	<p><u>Izmir Factory</u>                  Aegean Free Zone, Boss Sokak                  No:11, Gaziemir - Izmir, Turkey                  Tel : +90 232 252 2026                  Fax : +90 232 252 2027</p>	<p><u>Istanbul Export Sales Office</u>                  Ankara Yolu, Tuzla Tersane Kavşagi                  No:26 34947 Tuzla-Istanbul, Turkey                  Tel : +90 216 395 3460                  Fax : +90 216 395 5453                  Mail : info@cukurovapower.com</p>
	<p style="font-size: 0.8em;">All information in this document is substantially correct at time of printing and may be altered subsequently.</p>		