

CUKUROVA GENERATOR SYSTEMS

1500 Rpm, 50Hz, 400V

Volvo TAD940GE diesel engine

Newage/Stamford HCI444D alternator

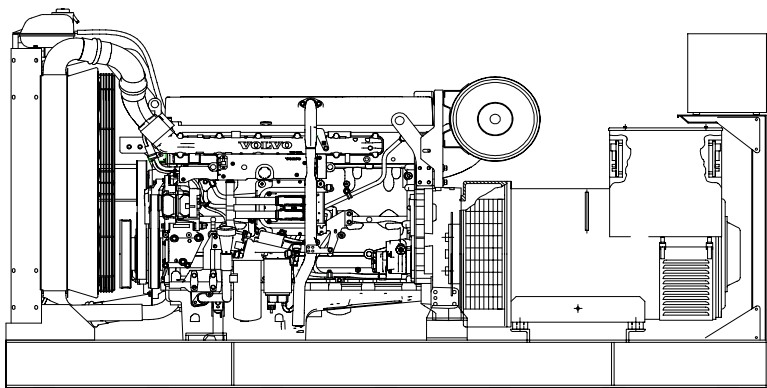

Standard Generator Features

- ◊ AMF, Automatic mains failure unit
- ◊ Heavy duty type, 6 cylinder, water cooled engine
- ◊ 55°C tropical type radiator
- ◊ Starter motor
- ◊ Lead acid battery
- ◊ Charging alternator
- ◊ Battery charge redressor
- ◊ Heavy duty, brushless type alternator
- ◊ Base frame with anti-vibration units
- ◊ Industrial type silencers
- ◊ Flexible exhaust compensator
- ◊ Block water heater unit
- ◊ Control panel with digital-automatic main control module
- ◊ Fan, fan drive, charging alternator drive and all rotating parts covered
- ◊ Radiator matrix covered by metal mesh against the mechanical damages
- ◊ Fabricated and welded steel base frame
- ◊ Anti-vibration mountings
- ◊ Engine and alternator manufacturer test reports
- ◊ Factory load, performance and function tests

Optional Features

- ◊ Automatic load transfer panel
- ◊ Automatic synchronization and power sharing systems
- ◊ Soundproof canopy
- ◊ Container type enclosures
- ◊ Road trailer
- ◊ Job-site trailer
- ◊ Protection circuit breaker
- ◊ Air start
- ◊ Remote type radiator
- ◊ Base fuel tank
- ◊ External type fuel tank
- ◊ Automatic fuel transfer system
- ◊ Residential silencer



Model	Standby		Prime	
	kVA	kW	kVA	kW
CJ300VN	306	245	278	222

APPLICATION DATA

Volvo TAD940GE Engine

Standard Features

The TAD940GE is a powerful, reliable and economical Generating Set Diesel built on the dependable in-line six design.

Durability & low noise

Designed for easiest, fastest and most economical installation. Well-balanced to produce smooth and vibration-free operation with low noise level. To maintain a controlled working temperature in cylinders and combustion chambers, the engine is equipped with piston cooling. The engine is also fitted with replaceable cylinder liners and valve seats/guides to ensure maximum durability and service life of the engine.

Operational economy and Low exhaust emission

The state of the art, high-tech injection and charging system with low internal losses contributes to excellent combustion and low fuel consumption. The TAD940GE complies with **TA-Luft** exhaust emission regulations.

Easy service & maintenance

Easily accessible service and maintenance points contribute to the ease of service of the engine.

Engine and Block

- ◊Optimized cast iron cylinder block with optimum distribution of forces without the block being unnecessary heavy.
- ◊Wet, replaceable cylinder liners
- ◊Piston cooling for low thermal load on pistons and reduced ring temperature
- ◊Tapered connecting rods for reduce risk of piston cracking
- ◊Crankshaft induction hardened bearing surfaces and fillets with seven bearings for moderate load on main and high-end bearings
- ◊Nitrocarburized transmission gears for heavy duty operation
- ◊Keystone top compression rings for long service life
- ◊Viscous type crankshaft vibration damper
- ◊Over head camshaft and four valves per cylinder equipped with camshaft damper to reduce noise and vibrations.
- ◊Replaceable valve guides and valve seats

Technical Specifications

Manufacturer	VOLVO
Model	TAD940GE
Type	4 cycle, water-cooled, diesel engine
Number of cylinders	6
Cylinder arrangement	Vertical in-line
Displacement, Liters	9.36
Bore X Stroke, mm	120 X 138
Compression Ratio	20.2:1
Combustion System	Direct injection
Aspiration	Turbocharged, air-to-air charge cooled
Rotation	Anti-clockwise viewed on flywheel
Gross engine power, kWb	277
Fan Power, kWm	12
BMEP gross, bar	24
Exhaust gas temp.(after turbo), °C	488
Exhaust gas flow (after turbo),m ³ / min	49.6
Mean piston speed, m / s	6.9

Model	Standby kW		Prime kW	
	Gross	Net	Gross	Net
TAD940GE	277	265	253	241

Cooling System

Type	Tropical, heavy duty type
Ambient temperature, °C	55
Engine+Radiator coolant cap., Liters	41
Jacket coolant flow, Liters / sec	5.5
Cooling airflow, kg / min	5.4 (at 55°C)
◊Air to air intercooler	
◊Belt driven, maintenance-free coolant pump with high degree of efficiency	
◊Efficient cooling with accurate coolant control through a water distribution duct in the cylinder block. Reliable sleeve thermostat with minimum pressure drop	
◊Coolant filter as standard	

Fuel System

Type of injection system	Direct injection
Fuel injector	Electronic unit injector
Delivery/hour at 1500rev/min, Liters	108
Governor type	Electronic / EMS2
◊Non-return fuel valve	
◊Fuel prefilter with water separator and water-in-fuel indicator / alarm	
◊Gear driven low-pressure fuel pump	
◊Fuel pressure switch	
◊Self de-aerating system. When replacing filters all fuel stays in the engine.	

Fuel Consumption

liters per hour	%100 Load	61.4 L
	%75 Load	44.5 L
	%50 Load	30.5 L
grams per kWh	%100 Load	204 g/kWh
	%75 Load	197 g/kWh
	%50 Load	203 g/kWh

Lubricating System

Type	Pressurized
Capacity, Liters	35
Lub oil pressure , bar	3.5-6
◊Full flow oil cooler	
◊Full flow disposable spin-on oil filter, for extra high filtration	
◊The lubricating oil level can be measured during operation	
◊Gear type lubricating oil pump, gear driven by the transmission	

Electrical System

Alternator	Bosh, 24 Volt 80A
Starter motor (DC)	Melco, 24 Volt
Starter motor power	5.5 kW
◊Engine Management System 2 (EMS 2), an electronically controlled processing system which optimizes engine performance. It also includes advanced facilities for diagnostics and fault tracing	
◊The instruments and controls connects to the engine via the CAN SAE J1939 interface and the Control Interface Unit (CIU).The CIU converts the digital CAN bus signal to an analog signal, making it possible to connect a variety of instruments.	
◊Sensors for oil pressure, oil temp, boost pressure, boost temp, coolant temp, fuel temp, water in fuel, fuel pressure and two speed sensors.	

Newage/Stamford HCI444D Alternator

Standard Features

Winding&Electrical Performance

All generator stators are wound to 2/3 pitch. This eliminates triplen (3rd, 9th, 15th...) harmonics on the voltage waveform and is found to be the optimum design for trouble-free supply of non-linear loads. The 2/3 pitch design avoids excessive neutral currents sometimes seen with higher winding pitches, when in parallel with the mains. A fully connected damper winding reduces oscillations during paralleling. This winding, with the 2/3 pitch and carefully selected pole and tooth designs, ensures very low waveform distortion.

SX440 AVR

With this self-excited system the main stator provides power via the Automatic Voltage Regulator (AVR) to the exciter stator. The high efficiency semi-conductors of the AVR ensure positive build-up from initial low levels of residual voltage.

The exciter rotor output is fed to the main rotor through a three-phase full-wave bridge rectifier. The rectifier is protected by a surge suppressor against surges caused, for example, by short circuit or out-of-phase paralleling.

The SX440 will support a range of electronic accessories, including a 'droop' Current Transformer (CT) to permit parallel operation with other ac generators. If 3-phase sensing is required with the self-excited system, the SX421 AVR must be used.

Terminals&Terminal Box

Standard generators are 3-phase reconnectable with 12 ends brought out to the terminals, which are mounted on a cover at the non-drive end of the generator. A sheet steel terminal box contains the AVR and provides ample space for the customers wiring and gland arrangements. It has removable panels for easy access.

Shaft&Keys

All generator rotors are dynamically balanced to better than BS6861:Part 1 Grade 2.5 for minimum vibration in operation. Two bearing generators are balanced with a half key.

Insulation / Impregnation

The insulation system is class 'H'

All wound components are impregnated with materials and processes designed specifically to provide the high build required for static windings and the high mechanical strength required for rotating components.

Standards

Newage Stamford industrial generators meet the requirements of **BS EN 60034** and the relevant section of other international standards such as **BS5000, VDE0530, NEMA MG1-32, IEC34, CSA C22.2-100, AS1359**. Other standards and certifications can be considered on request.

Quality Assurance

Generators are manufactured using production procedures having a quality assurance level to BS EN ISO 9001.

Model	Standby		Prime	
	kVA	kW	kVA	kW
HCI444D	330	264	300	240

Technical Specifications

Manufacturer	NEWAGE / STAMFORD
Model	HCI444D
Type	4-Poles, Rotating Field, Brushless
Standby power at rated voltage, kVA	330
Efficiency, %	%92.5
Power factor	0.8
Phase	3
Frequency, Hz	50
Speed, Rpm	1500
Voltage, V	380/415
Excitation	Self excited
Stator windings	2/3 Pitch factor
Regulation	AVR, Automatic Voltage Regulator
Voltage Regulator	SX440
Voltage Regulation, %	± 1
R.F.I Suppression	BS EN 61000-6-2 & BS EN 61000-6-4 VDE0875G, VDE 0875N
Waveform distortion	No Load <1.5% Non distorting balanced linear load<5.0%
Rotor	Dynamic balanced
Overspeed, Rpm	2250
Short circuit current	< 300%
TIF	Less than 50
Insulation class	H
Construction	Single bearing, direct coupled
Coupling	Flexible
Stator winding	Double layer concentric
Connection	WYE
Protection class	IP23
Cooling air volume, m ³ / sec	0.8

Optional Equipment

- ◊Optional Permanent Magnet Generator (PMG) provides an isolated power supply to the excitation control system
- ◊Anti Condensation Heaters
- ◊Air Filters
- ◊Temperature Indication RTD's
- ◊Winding Protection Thermistors
- ◊Quadrature Droop kit for Parallel Operation
- ◊SX421 AVR with 3 Phase Sensing and improved Regulation 0.5%
- ◊MX341 (PMG) 1% Regulation with 2 Phase Sensing
- ◊MX321 (PMG) with 3 Phase Sensing and improved Regulation 0.5%

Control Panel

Standard Equipments

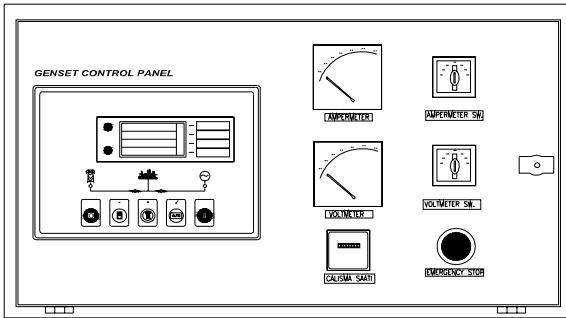

- ◊Deeapse 5220 digital automatic control module
- ◊Hourmeter
- ◊Voltmeter
- ◊Voltmeter commutator
- ◊Ammeter
- ◊Ammeter commutator
- ◊Emergency stop button

Deepsea 5220 Control Module

Description

- ◊The model 5220 is an Automatic Mains Failure Control module.
- ◊The modul is used to monitor a mains supply and automatically start a standby generator set.
- ◊The module also provides indication of operational status and fault conditions automatically shutting down the genset and indicating failures by means of an LCD display, and appropriate flashing LED on the front panel.
- ◊Selected timers and alarms can be altered by the user from the front panel.
- ◊Alterations to the system are made using the 810 interface and a PC. This interface also provides real time diagnostic facilities

Specifications

- ◊240mm x 172mm dimensions
- ◊70mm x 40mm dimensions, 4 segment grafical LCD monitor
- ◊Developed 16-bit Microprocessor design
- ◊Easy comprehended display (Hid-Til-Lit SMD LED technology)
- ◊LED mimic diagram
- ◊SMS messaging capability with suitable GSM Modem
- ◊PC software is MS Windows based and allows the operator to control the module from a remote location (P810 Software Kit necessary)
- ◊Easy pushbutton controls
- ◊System parameters can be adjusted manually from the front panel
- ◊kVA,kW ve Cosφ measurements
- ◊Communication with MODEM

Pushbutton Controls

STOP / START
 AUTO, TEST, MANUAL
 LCD PAGE

Input Functions display on LCD

Generator Volts	Volts L1-N, L2-N, L3-N
Generator Volts	Volts L1-L2, L2-L3, L3-L1
Generator Amps	Amps L1, L2, L3
Generator Frequency	Hz
Mains Volts	Volts L1-N, L2-N, L3-N
Mains Volts	Volts L1-L2, L2-L3, L3-L1
Mains Frequency	Hz
Engine Speed	RPM
Plant Battery Volts	Volts
Engine Hours Run	Hour
Generator total power	kVA L1, L2, L3,total
Generator total power	KW L1, L2, L3,total
Generator power factor	Cosφ L1, L2, L3,total

Optional Input Functions

Engine Oil pressure	kPa
Fuel level	%
Engine Temperature	°C

Alarm Channels

Under/over generator voltage
 Over-current
 Under/over generator frequency
 Under/over speed
 Charge fail
 Emergency stop
 Low oil pressure
 High engine temperature
 Fail to start
 Low/high DC battery voltage
 Reverse power
 Generator phase rotation error
 Generator short-circuit protection
 Loss of speed sensing signal
 Mains out of limits

Environmental Testing Standards

Electromagnetic Compatibility

BS EN 50081-2:1992 and EN 61000-6-4:2000 EMC, Emission Standards for the Industrial Environment

EN 61000-6-2:1999 EMC, Immunity Standards for the Industrial Environment

Vibration

BS EN 60068-2-6 Ten sweeps (up and back down) at 1 octave/minute in each of the three major axes.

5Hz to @ +/-7.5mm constant displacement.

8Hz to 500Hz 2gn constant acceleration.

Temperature

Cold : BS EN 60068-2-1 to -30°C

Hot : BS EN 60068-2-2 to 70°C

Humidity

BS EN 2011 part 2.1 93% RH @ 40° for 48 hours

Shock

BS EN 6068-2-27 Three half sine shocks in each of the three major axes 15gn amplitude.11mS duration.

Electrical Safety

BS EN 60950 Low Voltage Directive/Safety of information technology equipments, including electrical business equipment

Model Codes and General Information

Cukurova Diesel Generator

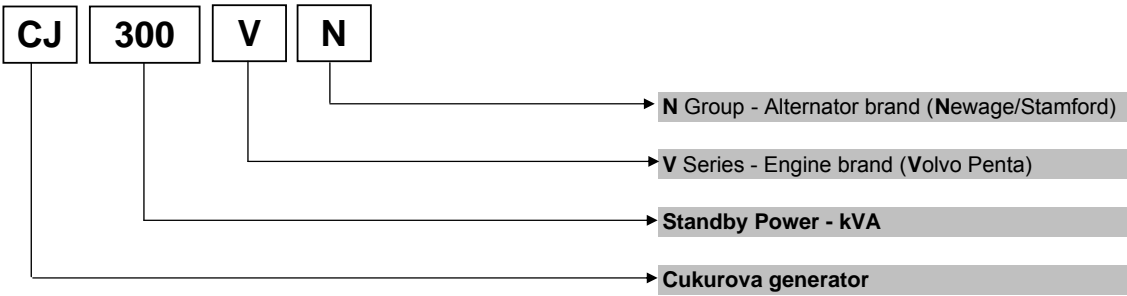

Volvo Penta Diesel Engine

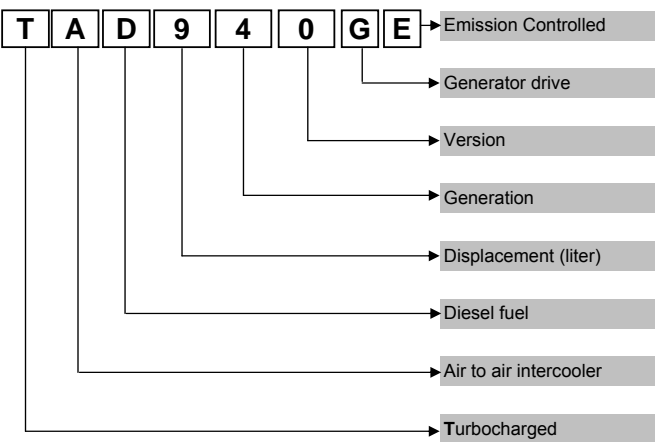

Newage/Stamford Alternator

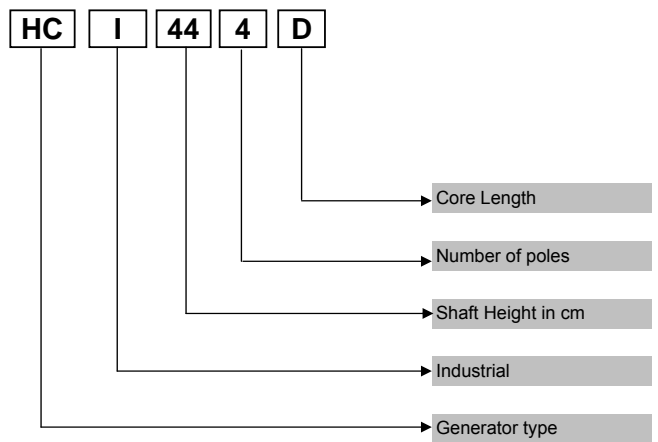

Information

Power Ratings

Standby power rating is for the supply of emergency power at variable load for the duration of the non-availability of the mains power supply. No overload capacity is available at this rating. A standby rated engine should be sized for an average load factor of 80% based on published standby rating for 500 operating hours per year. Standby ratings should never be applied except in true emergency power failure conditions.

Prime power rating is available for unlimited hours per year with a variable load of which the average engine load factor is 80% of the published power rating, incorporation of a 10% overload for 1 hour in every 12 hours of operation which permitted

Continuous power rating is available for continuous full load operation. No overload is permitted.

Acc. to ISO 3046/1, BS 5514, DIN6271

Electric Formulas

Values	Formula	
kWe	kWm X E	
kWe	$(U \times I \times 1.73 \times pf) / 1000$	kVA x pf
kVA	$(U \times I \times 1.73) / 1000$	kWe / pf
I (Amp)	$(kWe \times 1000) / (U \times 1.73 \times pf)$	$(kVA \times 1000) / (U \times 1.73)$
Frequency	$(Rpm \times N^{\circ}Pole) / (2 \times 60)$	
Rpm	$(2 \times 60 \times Frequency) / N^{\circ}Pole$	

kWm: Mechanical Power
kWe : Electrical Power
pf : Power factor
E : Alternator efficiency

I : Current (A)
U : Voltage (V)
kVA : Power
Rpm: Revolutions per minute

General Dimensions

Standard Generator

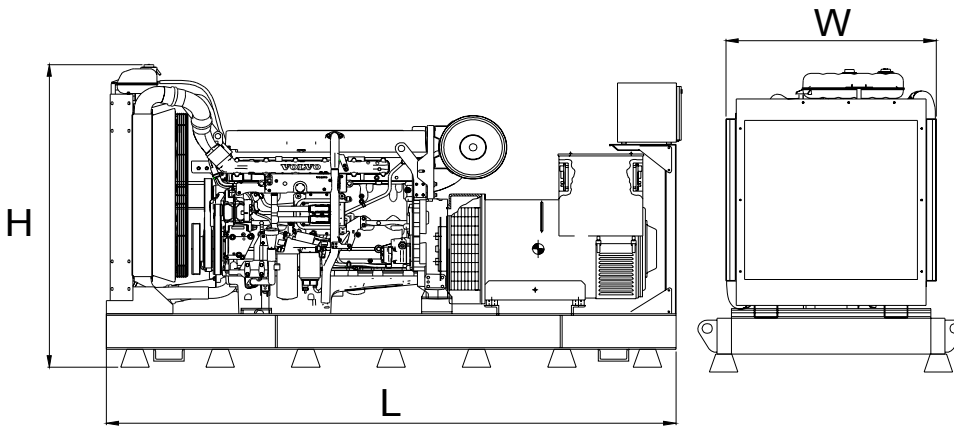

Length, L	3 m
Height, H	1,7 m
Width, W	1,1 m
Weight, Total	2900 kg

Generator with Soundproof Canopy

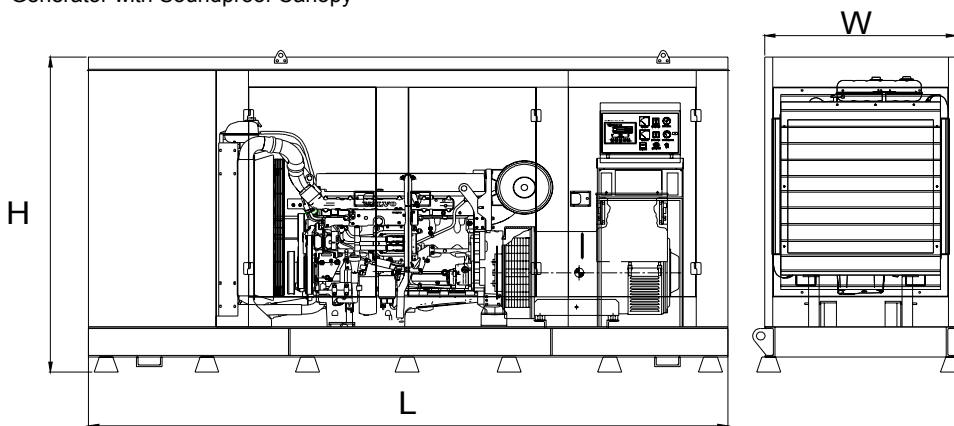

Length, L	4 m
Height, H	2,2 m
Width, W	1,2 m
Weight, Total	3600 kg

Generator Room Layout

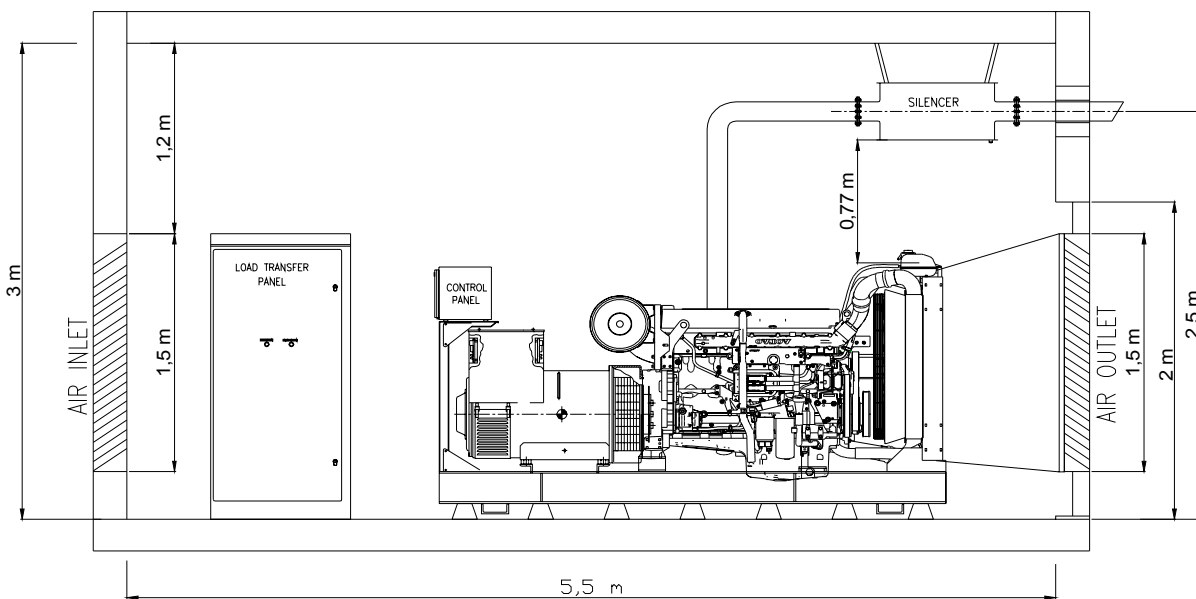

Above drawings dimensions and weights are only for guidance. For installation design of your specific application, necessary certified drawings, at site consultancy service as well as maintenance and installations manuals will be provided by Cukurova without any charge.

Specifications may change without notice



CUKUROVA JENERATOR SANAYII TICARET A.S.

Izmir Factory
Aegean Free Zone, Boss Sokak
No:11, Gaziemir - Izmir, Turkey
Tel : +90 232 252 2026
Fax : +90 232 252 2027

Istanbul Export Sales Office
Ankara Yolu, Tuzla Tersane Kavşagi
No:26 34947 Tuzla-Istanbul, Turkey
Tel : +90 216 395 3460
Fax : +90 216 395 5453
Mail : info@cukurovapower.com