

CUKUROVA GENERATOR SYSTEMS

1500 Rpm, 50Hz, 400V

Volvo TAD941GE diesel engine

Leroy Somer LSA 47.2 VS2 alternator

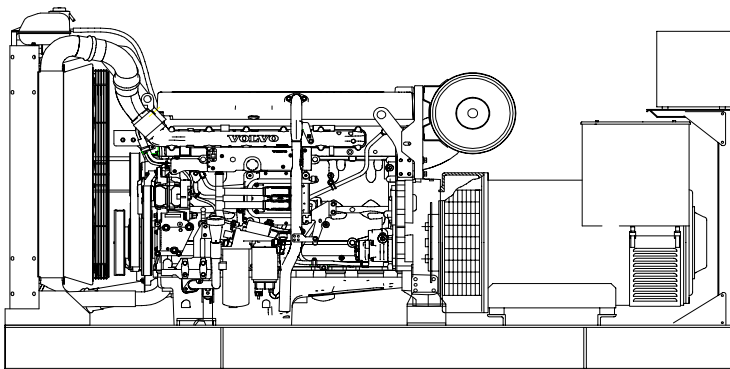

Standard Generator Features

- ◊ AMF, Automatic mains failure unit
- ◊ Heavy duty type, 6 cylinder, water cooled engine
- ◊ 55°C tropical type radiator
- ◊ Starter motor
- ◊ Lead acid battery
- ◊ Charging alternator
- ◊ Battery charge redressor
- ◊ Heavy duty, brushless type alternator
- ◊ Base frame with anti-vibration units
- ◊ Industrial type silencers
- ◊ Flexible exhaust compensator
- ◊ Block water heater unit
- ◊ Control panel with digital-automatic main control module
- ◊ Fan, fan drive, charging alternator drive and all rotating parts covered
- ◊ Radiator matrix covered by metal mesh against the mechanical damages
- ◊ Fabricated and welded steel base frame
- ◊ Anti-vibration mountings
- ◊ Engine and alternator manufacturer test reports
- ◊ Factory load, performance and function tests

Optional Features

- ◊ Automatic load transfer panel
- ◊ Automatic synchronization and power sharing systems
- ◊ Soundproof canopy
- ◊ Container type enclosures
- ◊ Road trailer
- ◊ Job-site trailer
- ◊ Protection circuit breaker
- ◊ Air start
- ◊ Remote type radiator
- ◊ Base fuel tank
- ◊ External type fuel tank
- ◊ Automatic fuel transfer system
- ◊ Residential silencer



Model	Standby		Prime	
	kVA	kW	kVA	kW
CJ350VL	360	288	328	262

APPLICATION DATA

Volvo TAD941GE Engine

Standard Features

The TAD941GE is a powerful, reliable and economical Generating Set Diesel built on the dependable in-line six design.

Durability & low noise

Designed for easiest, fastest and most economical installation. Well-balanced to produce smooth and vibration-free operation with low noise level. To maintain a controlled working temperature in cylinders and combustion chambers, the engine is equipped with piston cooling. The engine is also fitted with replaceable cylinder liners and valve seats/guides to ensure maximum durability and service life of the engine.

Low exhaust emission

The state of the art, high-tech injection and charging system with low internal losses contributes to excellent combustion and low fuel consumption. The TAD941GE complies with EU stage2 and TA-luft exhaust emission regulations.

Easy service & maintenance

Easily accessible service and maintenance points contribute to the ease of service of the engine.

Engine and Block

- ◊Optimized cast iron cylinder block with optimum distribution of forces without the block being unnecessary heavy.
- ◊Wet, replaceable cylinder liners
- ◊Piston cooling for low thermal load on pistons and reduced ring temperature
- ◊Tapered connecting rods for reduce risk of piston cracking
- ◊Crankshaft induction hardened bearing surfaces and fillets with seven main bearings for moderate load on main and high-end bearings
- ◊Nitrocarburized transmission gears for heavy duty operation
- ◊Keystone top compression rings for long service life
- ◊Viscous type crankshaft vibration damper
- ◊Over head camshaft and four valves per cylinder equipped with camshaft damper to reduce noise and vibrations.

Technical Specifications

Manufacturer	VOLVO
Model	TAD941GE
Type	4 cycle, water-cooled, diesel engine
Number of cylinders	6
Cylinder arrangement	Vertical in-line
Displacement, Liters	9.36
Bore X Stroke, mm	120 X 138
Compression Ratio	17.4:1
Combustion System	Direct injection
Aspiration	Turbocharged, air-to-air charge cooled
Rotation	Anti-clockwise viewed on flywheel
Gross engine power, kWb	323
Fan Power, kWm	13
Exhaust gas temp.(after turbo), °C	539
Exhaust gas flow (after turbo),m ³ / min	52.2
Mean piston speed, m / s	6.9

Model	Standby kW		Prime kW	
	Gross	Net	Gross	Net
TAD941GE	323	310	294	281

Cooling System

Type	Tropical, heavy duty type
Ambient temperature, °C	55
Engine+Radiator coolant cap., Liters	41
Jacket coolant flow, Liters / sec	5.5

- ◊Air to air intercooler
- ◊Belt driven, maintenance-free coolant pump with high degree of efficiency
- ◊Efficient cooling with accurate coolant control through a water distribution duct in the cylinder block. Reliable sleeve thermostat with minimum pressure drop
- ◊Coolant filter as standard

Fuel System

Type of injection system	Direct injection
Fuel injector	Electronic unit injector
Delivery/hour at 1500rev/min, Liters	108
Governor type	Electronic / EMS2
◊Non-return fuel valve	
◊Fuel prefilter with water separator and water-in-fuel indicator / alarm	
◊Gear driven low-pressure fuel pump	
◊Fuel pressure switch	
◊Self de-aerating system. When replacing filters all fuel stays in the engine.	

Fuel Consumption

grams per kWh	%100 Load	204 g/kWh
	%75 Load	200 g/kWh
	%50 Load	205 g/kWh
	%25 Load	226 g/kWh

Lubricating System

Type	Pressurized
Capacity, Liters	35
Lub oil pressure , kPa	350 - 600
◊Full flow oil cooler	
◊Full flow disposable spin-on oil filter, for extra high filtration	
◊The lubricating oil level can be measured during operation	
◊Gear type lubricating oil pump, gear driven by the transmission	

Electrical System

Alternator	Bosh, 24 Volt 80A
Starter motor (DC)	Melco, 24 Volt
Starter motor power	5.5 kW
◊Engine Management System 2 (EMS 2), an electronically controlled processing system which optimizes engine performance. It also includes advanced facilities for diagnostics and fault tracing	
◊The instruments and controls connects to the engine via the CAN SAE J1939 interface and the Control Interface Unit (CIU).The CIU converts the digital CAN bus signal to an analog signal, making it possible to connect a variety of instruments.	
◊Sensors for oil pressure, oil temp, boost pressure, boost temp, coolant temp, fuel temp, water in fuel, fuel pressure and two speed sensors.	

Leroy Somer LSA 47.2 VS2 Alternator

Standard Features

Top of the Range Electrical Performance

Class H insulation
 Standard 12-wire re-connectable winding, 2/3 pitch
 High efficiency and motor starting capacity
 R 791 interference suppression conforming to standard EN 55011 group 1
 class B standard for European zone (CE marking)

Protection System Suited to the Environment

The LSA 47.2 is IP23

Reinforced Mechanical Structure Using Finite Element Modelling

Compact and rigid assembly to better withstand generator-set vibrations
 Steel frame
 Cast iron flanges and shields
 Two-bearing and single bearing versions designed to be suitable for engines on the market
 Half-key balancing
 Greased for life bearings (regreasable bearings optional)

Accessible Terminal Box Proportioned for Optional Equipment

Easy access to the voltage regulator and to the connections
 Possible inclusion of accessories for paralleling, protection and measurement
 8-way terminal block for voltage reconnection

Compliant with International Standards

The LSA 47.2 alternator conforms to the main international standards and regulations:

IEC 60034, NEMA MG 1.22, ISO 8528, CSA, CSA/UL

It can be integrated into a CE marked generator set

The LSA 47.2 is designed, manufactured and marketed in an ISO 9001 environment

Model	Standby		Prime	
	kVA	kW	kVA	kW
LSA 47.2 VS2	420	336	365	292

Technical Specifications

Manufacturer	LEROY SOMER
Model	LSA 47.2 VS2
Type	4-Poles, Rotating Field, Brushless
Standby power at rated voltage, kVA	420
Efficiency, %	93
Power factor	0.8
Phase	3
Frequency, Hz	50
Speed, Rpm	1500
Voltage, V	400
Excitation	SHUNT(12 wire)
Stator windings	2/3 Pitch factor
Regulation	AVR, Automatic Voltage Regulator
Voltage Regulator	R 230
Voltage Regulation, %	± 0.5
Total HarmonicTGH / THC	at no load<1.5% - on load<2%
Waveform: NEMA = TIF	< 50
Waveform: I.E.C = THF,	< 2%
Insulation class	H
Overspeed, Rpm	2250
Construction	Single bearing, direct coupled
Coupling	Flexible
Amortisseur Windings	Full
Connection	WYE
Rotor	Dynamic balanced
Protection class	IP23
Air flow, m ³ / min	0,9

Optional Equipment

- ◊Filters on air inlet and air outlet (IP44)
- ◊Windign protection for clean environmetns with relative humidity greater than 95%
- ◊Space heaters
- ◊Thermal protection for winding
- ◊Digital voltage regulator
- ◊PMG system

Control Panel

Standard Equipments

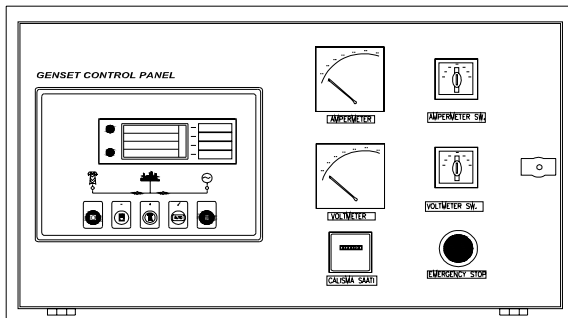

- ◊Deeapse 5220 digital automatic control module
- ◊Hourmeter
- ◊Voltmeter
- ◊Voltmeter commutator
- ◊Ammeter
- ◊Ammeter commutator
- ◊Emergency stop button

Deepsea 5220 Control Module

Description

- ◊The model 5220 is an Automatic Mains Failure Control module.
- ◊The module is used to monitor a mains supply and automatically start a standby generator set.
- ◊The module also provides indication of operational status and fault conditions automatically shutting down the genset and indicating failures by means of an LCD display, and appropriate flashing LED on the front panel.
- ◊Selected timers and alarms can be altered by the user from the front panel.
- ◊Alterations to the system are made using the 810 interface and a PC. This interface also provides real time diagnostic facilities

Specifications

- ◊240mm x 172mm dimensions
- ◊70mm x 40mm dimensions, 4 segment graphical LCD monitor
- ◊Developed 16-bit Microprocessor design
- ◊Easy comprehended display (Hid-Til-Lit SMD LED technology)
- ◊LED mimic diagram
- ◊SMS messaging capability with suitable GSM Modem
- ◊PC software is MS Windows based and allows the operator to control the module from a remote location (P810 Software Kit necessary)
- ◊Easy pushbutton controls
- ◊System parameters can be adjusted manually from the front panel
- ◊kVA, kW ve Cosφ measurements
- ◊Communication with MODEM

Pushbutton Controls

STOP / START
 AUTO, TEST, MANUAL
 LCD PAGE

Input Functions display on LCD

Generator Volts	Volts L1-N, L2-N, L3-N
Generator Volts	Volts L1-L2, L2-L3, L3-L1
Generator Amps	Amps L1, L2, L3
Generator Frequency	Hz
Mains Volts	Volts L1-N, L2-N, L3-N
Mains Volts	Volts L1-L2, L2-L3, L3-L1
Mains Frequency	Hz
Engine Speed	RPM
Plant Battery Volts	Volts
Engine Hours Run	Hour
Generator total power	kVA L1, L2, L3, total
Generator total power	KW L1, L2, L3, total
Generator power factor	Cosφ L1, L2, L3, total

Optional Input Functions

Engine Oil pressure	kPa
Fuel level	%
Engine Temperature	°C

Alarm Channels

Under/over generator voltage
 Over-current
 Under/over generator frequency
 Under/over speed
 Charge fail
 Emergency stop
 Low oil pressure
 High engine temperature
 Fail to start
 Low/high DC battery voltage
 Reverse power
 Generator phase rotation error
 Generator short-circuit protection
 Loss of speed sensing signal
 Mains out of limits

Environmental Testing Standards

Electromagnetic Compatibility

BS EN 50081-2:1992 and EN 61000-6-4:2000 EMC, Emission Standards for the Industrial Environment

EN 61000-6-2:1999 EMC, Immunity Standards for the Industrial Environment

Vibration

BS EN 60068-2-6 Ten sweeps (up and back down) at 1 octave/minute in each of the three major axes.

5Hz to @ +/-7.5mm constant displacement.

8Hz to 500Hz 2gn constant acceleration.

Temperature

Cold : BS EN 60068-2-1 to -30°C

Hot : BS EN 60068-2-2 to 70°C

Humidity

BS EN 2011 part 2.1 93% RH @ 40° for 48 hours

Shock

BS EN 6068-2-27 Three half sine shocks in each of the three major axes 15gn amplitude. 11ms duration.

Electrical Safety

BS EN 60950 Low Voltage Directive/Safety of information technology equipments, including electrical business equipment

Model Codes and General Information

Cukurova Diesel Generator

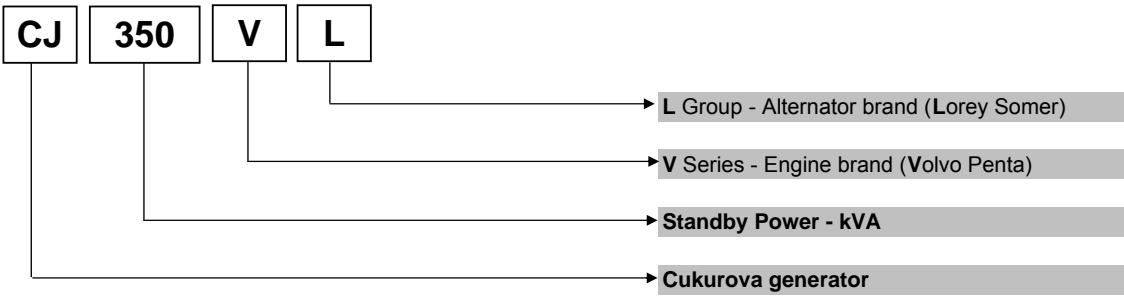

Volvo Penta Diesel Engine

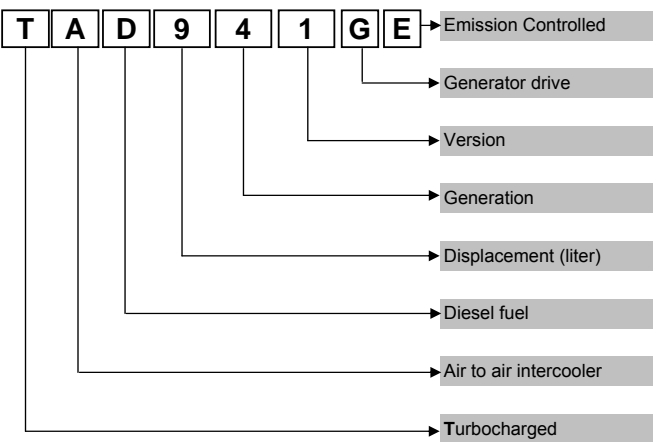

Leroy Somer Alternator

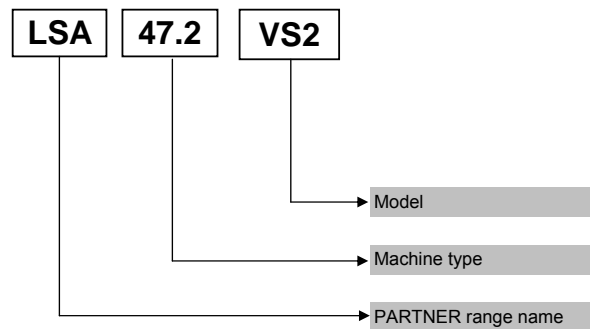

Information

Power Ratings

Standby power rating is for the supply of emergency power at variable load for the duration of the non-availability of the mains power supply. No overload capacity is available at this rating. A standby rated engine should be sized for an average load factor of 80% based on published standby rating for 500 operating hours per year. Standby ratings should never be applied except in true emergency power failure conditions.

Prime power rating is available for unlimited hours per year with a variable load of which the average engine load factor is 80% of the published power rating, incorporation of a 10% overload for 1 hour in every 12 hours of operation which permitted

Continuous power rating is available for continuous full load operation. No overload is permitted.

Acc. to ISO 3046/1, BS 5514, DIN6271

Electric Formulas

Values	Formula	
kWe	kWm X E	
kWe	$(U \times I \times 1.73 \times pf) / 1000$	kVA x pf
kVA	$(U \times I \times 1.73) / 1000$	kWe / pf
I (Amp)	$(kWe \times 1000) / (U \times 1.73 \times pf)$	$(kVA \times 1000) / (U \times 1.73)$
Frequency	$(Rpm \times N^{\circ}Pole) / (2 \times 60)$	
Rpm	$(2 \times 60 \times Frequency) / N^{\circ}Pole$	

kWm: Mechanical Power
kWe : Electrical Power
pf : Power factor
E : Alternator efficiency

I : Current (A)
U : Voltage (V)
kVA : Power
Rpm: Revolutions per minute

General Dimensions

Standard Generator

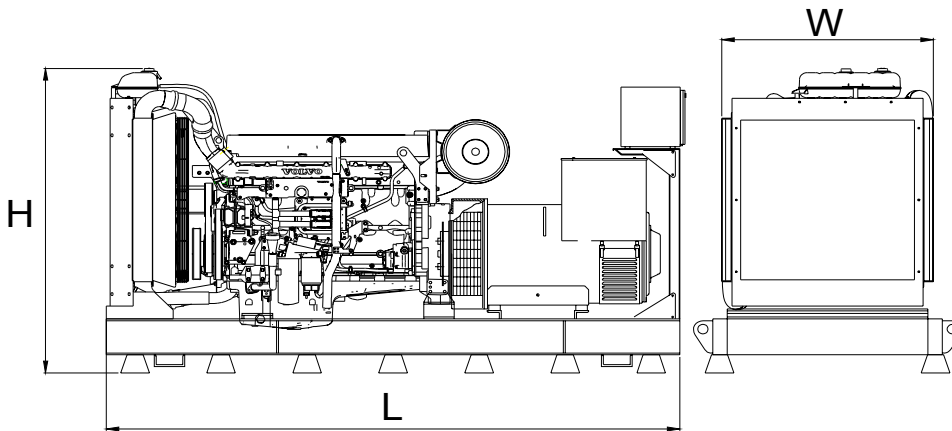

Length, L	3 m
Height, H	1,7 m
Width, W	1,1 m
Weight, Total	3150 kg

Generator with Soundproof Canopy

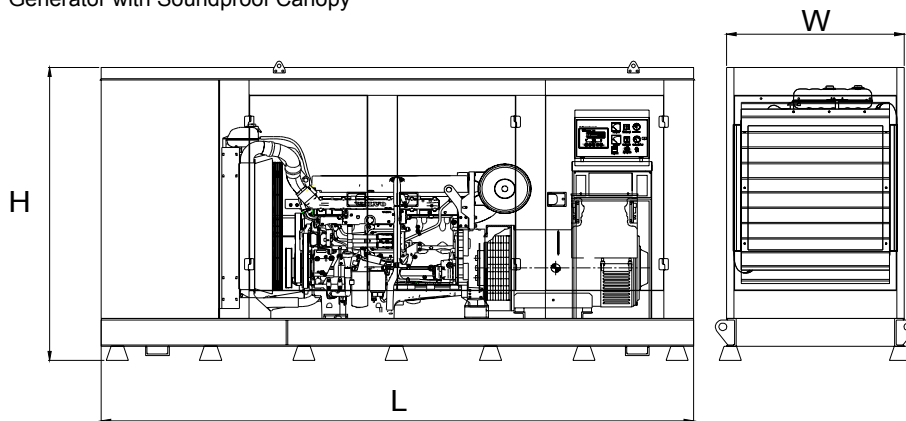

Length, L	4,5 m
Height, H	2,5 m
Width, W	1,4 m
Weight, Total	4350 kg

Generator Room Layout

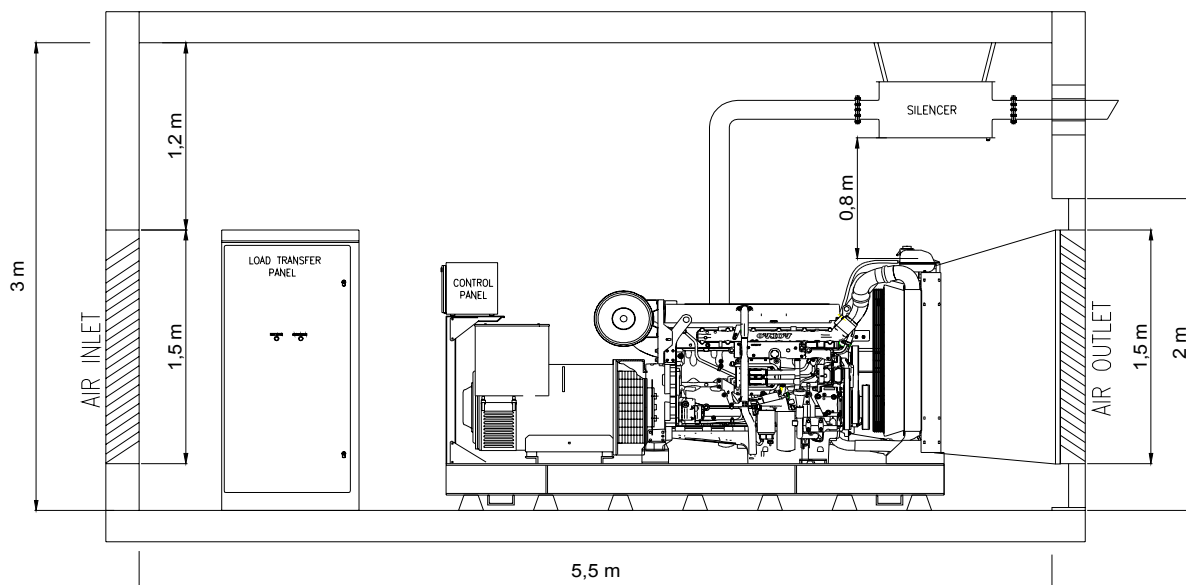

Above drawings dimensions and weights are only for guidance. For installation design of your specific application, necessary certified drawings, at site consultancy service as well as maintenance and installations manuals will be provided by Cukurova without any charge.

Specifications may change without notice

	CUKUROVA JENERATOR SANAYII TICARET A.S.	
	<p>Izmir Factory Aegean Free Zone Boss Sokak No:11, Gaziemir Izmir, Turkey Tel : +90 232 252 20 26 Fax : +90 232 252 20 27</p>	<p>Istanbul Export Sales Office Ebulula Mardin Caddesi Maya Meridyen İş Merkezi Kat:4 No: 14 Akatlar Istanbul, Turkey Tel : +90 212 352 70 90 Fax : +90 212 352 12 77 E-mail : info@cukurovapower.com</p>