

Perkins 2506A-E15TAG1 diesel engine

Newage/Stamford HCI544C alternator

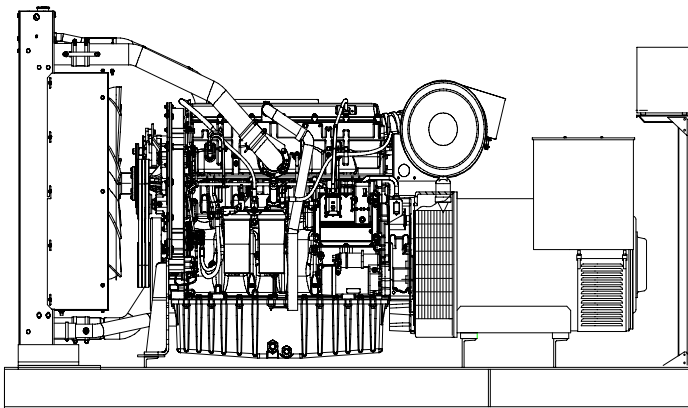

**Standard Generator Features**

- ◊ AMF, Automatic mains failure unit
- ◊ Heavy duty type, 6 cylinder, water cooled engine
- ◊ 50°C tropical type radiator
- ◊ Starter motor
- ◊ Lead acid battery
- ◊ Charging alternator
- ◊ Battery charge redressor
- ◊ Heavy duty, brushless type alternator
- ◊ Base frame with anti-vibration units
- ◊ Industrial type silencers
- ◊ Flexible exhaust compensator
- ◊ Block water heater unit
- ◊ Control panel with digital-automatic main control module
- ◊ Fan, fan drive, charging alternator drive and all rotating parts covered
- ◊ Radiator matrix covered by metal mesh against the mechanical damages
- ◊ Fabricated and welded steel base frame
- ◊ Anti-vibration mountings
- ◊ Engine and alternator manufacturer test reports
- ◊ Factory load, performance and function tests

**Optional Features**

- ◊ Automatic load transfer panel
- ◊ Automatic synchronization and power sharing systems
- ◊ Soundproof canopy
- ◊ Container type enclosures
- ◊ Road trailer
- ◊ Job-site trailer
- ◊ Protection circuit breaker
- ◊ Air start
- ◊ Remote type radiator
- ◊ Base fuel tank
- ◊ External type fuel tank
- ◊ Automatic fuel transfer system
- ◊ Residential silencer



Model	Standby		Prime	
	kVA	kW	kVA	kW
<b>CJ500PN</b>	<b>509</b>	<b>407</b>	<b>463</b>	<b>370</b>

**APPLICATION DATA**

**Perkins 2506A-E15TAG1 Engine**

**Standard Features**

**Economic power**

◊Mechanically operated unit fuel injectors with advanced electronic control, combined with carefully matched turbocharging, give excellent fuel atomisation which leads to exceptional low fuel consumption.

**Reliable power**

◊Developed and tested using the latest engineering techniques and finite element analysis for high reliability.  
 ◊Low oil usage and low wear rates.  
 ◊High compression ratio ensures clean rapid starting in all conditions.  
 ◊Support comes from a worldwide network of 4,000 distributors and dealers.

**Compact, clean and efficient power**

◊Exceptional power to weight ratio and compact size gives optimum power density for ease of installation and more cost effective transportation.  
 ◊Designed to provide excellent service access for ease of maintenance.

**Standards**

◊ UK MOD, BS5750, ISO9001, BS5514/1-1982, ISO 3046/1, ISO 8528/1

**Technical Specifications**

Manufacturer	PERKINS
Model	2506A-E15TAG1
Type	4 cycle, water-cooled, diesel engine
Number of cylinders	6
Cylinder arrangement	Vertical in-line
Displacement, Liters	15.2
Bore X Stroke, mm	137 X 171
Compression Ratio	16:1
Combustion System	Direct injection
Aspiration	Turbocharged, air-to-air charge cooled
Rotation	Anti-clockwise viewed on flywheel
Gross engine power, kWb	459
Fan Power, kWm	16
BMEP gross, bar	24,47
Combustion air flow, m <sup>3</sup> / min	30.5
Exhaust gas temp.(after turbo), °C	514
Exhaust gas flow (after turbo),m <sup>3</sup> / min	81
Mean piston speed, m / s	8

**Cooling System**

Type	Tropical, heavy duty type
Ambient temperature, °C	50
Engine+Radiator coolant cap., Liters	58
Jacket coolant flow, Liters / sec	5.2
Cooling min airflow, m <sup>3</sup> / min	576 (at 50°C)
◊Gear-driven circulating pump	
◊Mounted belt-driven pusher fan	
◊Radiator supplied loose incorporating air-to-air charge cooler	
◊System designed for ambients up to 50°C	

Model	Standby kW		Prime kW	
	Gross	Net	Gross	Net
<b>2506A-E15TAG1</b>	<b>459</b>	<b>435</b>	<b>419</b>	<b>395</b>

**Lubricating System**

Type	Pressurized
Capacity, Liters	62
Lub oil pressure (min), kPa	200
◊Wet sump with filler and dipstick	
◊Full-flow replaceable 'Ecoplus' filter	
◊Oil cooler integral with filter header	

**Fuel System**

Type of injection system	MEUI
Fuel injector	MEUI
Delivery/hour at 1500rev/min, Liters	413
Governor type	Electronic, governing to ISO 8528-5 class G3
◊Mechanically actuated electronically controlled unit fuel injectors with full authority electronic control	
◊Replaceable 'Ecoplus' fuel filter elements with primary filter/water separator	
◊Fuel cooler	

**Electrical System**

Alternator	24 Volt with integral regulator
Starter motor (DC)	24 Volt
Starter motor power	7.5 kW
◊ECM mounted on engine with wiring looms and sensors	
◊3 level engine protection system	

**Fuel Consumption**

liters per hour	%110 Load	107 L
	%100 Load	97 L
	%75 Load	75 L
	%50 Load	53.5 L
grams per kWh	%110 Load	202 g/kWh
	%100 Load	203 g/kWh
	%75 Load	210 g/kWh
	%50 Load	219 g/kWh

**Optional Equipments**

- ◊Additional speed sensor
- ◊Temperature and pressure sensors for gauges
- ◊Air filter rain hood
- ◊Twin starters/facility for second starter
- ◊Closed circuit crankcase ventilation system

## Newage/Stamford HCI544C Alternator

### Standard Features

#### Winding&Electrical Performance

All generator stators are wound to 2/3 pitch. This eliminates triplen (3rd, 9th, 15th...) harmonics on the voltage waveform and is found to be the optimum design for trouble-free supply of non-linear loads. The 2/3 pitch design avoids excessive neutral currents sometimes seen with higher winding pitches, when in parallel with the mains. A fully connected damper winding reduces oscillations during paralleling. This winding, with the 2/3 pitch and carefully selected pole and tooth designs, ensures very low waveform distortion.

#### SX440 AVR

With this self-excited system the main stator provides power via the Automatic Voltage Regulator (AVR) to the exciter stator. The high efficiency semi-conductors of the AVR ensure positive build-up from initial low levels of residual voltage.

The exciter rotor output is fed to the main rotor through a three-phase full-wave bridge rectifier. The rectifier is protected by a surge suppressor against surges caused, for example, by short circuit or out-of-phase paralleling.

The SX440 will support a range of electronic accessories, including a 'droop' Current Transformer (CT) to permit parallel operation with other ac generators. If 3-phase sensing is required with the self-excited system, the SX421 AVR must be used.

#### Terminals&Terminal Box

Standard generators are 3-phase reconnectable with 12 ends brought out to the terminals, which are mounted on a cover at the non-drive end of the generator. A sheet steel terminal box contains the AVR and provides ample space for the customer's wiring and gland arrangements. It has removable panels for easy access.

#### Shaft&Keys

All generator rotors are dynamically balanced to better than BS6861:Part 1 Grade 2.5 for minimum vibration in operation. Two bearing generators are balanced with a half key.

#### Insulation / Impregnation

The insulation system is class 'H'

All wound components are impregnated with materials and processes designed specifically to provide the high build required for static windings and the high mechanical strength required for rotating components.

#### Standards

Newage Stamford industrial generators meet the requirements of **BS EN 60034** and the relevant section of other international standards such as **BS5000, VDE0530, NEMA MG1-32, IEC34, CSA C22.2-100, AS1359**. Other standards and certifications can be considered on request.

#### Quality Assurance

Generators are manufactured using production procedures having a quality assurance level to BS EN ISO 9001.

Model	Standby		Prime	
	kVA	kW	kVA	kW
<b>HCI544C</b>	<b>520</b>	<b>416</b>	<b>500</b>	<b>400</b>

### Technical Specifications

Manufacturer	NEWAGE / STAMFORD
Model	HCI544C
Type	4-Poles, Rotating Field, Brushless
Standby power at rated voltage, kVA	520
Efficiency, %	%93.6
Power factor	0.8
Phase	3
Frequency, Hz	50
Speed, Rpm	1500
Voltage, V	380/415
Excitation	Self excited
Stator windings	2/3 Pitch factor
Regulation	AVR, Automatic Voltage Regulator
Voltage Regulator	SX440
Voltage Regulation, %	± 1
R.F.I Suppression	BS EN 61000-6-2 & BS EN 61000-6-4 VDE0875G, VDE 0875N
Waveform distortion	No Load <1.5% Non distorting balanced linear load <5.0%
Rotor	Dynamic balanced
Overspeed, Rpm	2250
Short circuit current	< 300%
TIF	Less than 50
Insulation class	H
Construction	Single bearing, direct coupled
Coupling	Flexible
Stator winding	Double layer concentric
Connection	WYE
Protection class	IP23
Cooling air volume, m <sup>3</sup> / sec	1.035

### Optional Equipment

- ◊Optional Permanent Magnet Generator (PMG) provides an isolated power supply to the excitation control system
- ◊Anti Condensation Heaters
- ◊Air Filters
- ◊Temperature Indication RTD's
- ◊Winding Protection Thermistors
- ◊Quadrature Droop kit for Parallel Operation
- ◊SX421 AVR with 3 Phase Sensing and improved Regulation 0.5%
- ◊MX341 (PMG) 1% Regulation with 2 Phase Sensing
- ◊MX321 (PMG) with 3 Phase Sensing and improved Regulation 0.5%

## Control Panel

### Standard Equipments

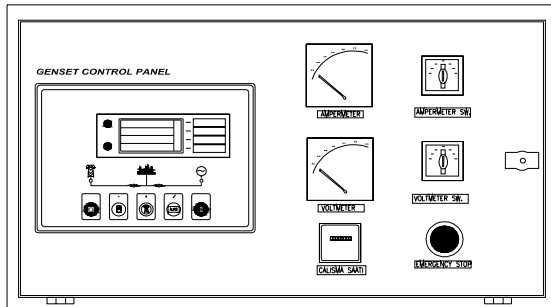

- ◊ Deepsea 5220 digital automatic control module
- ◊ Hourmeter
- ◊ Voltmeter
- ◊ Voltmeter commutator
- ◊ Amperemeter
- ◊ Amperemeter commutator
- ◊ Emergency stop button

### Deepsea 5220 Control Module

#### Description

- ◊ The model 5220 is an Automatic Mains Failure Control module.
- ◊ The modul is used to monitor a mains supply and automatically start a standby generator set.
- ◊ The module also provides indication of operational status and fault conditions automatically shutting down the genset and indicating failures by means of an LCD display, and appropriate flashing LED on the front panel.
- ◊ Selected timers and alarms can be altered by the user from the front panel.
- ◊ Alterations to the system are made using the 810 interface and a PC. This interface also provides real time diagnostic facilities

### Specifications

- ◊ 240mm x 172mm dimensions
- ◊ 70mm x 40mm dimensions, 4 segment grafical LCD monitor
- ◊ Developed 16-bit Microprocessor design
- ◊ Easy comprehended display (Hid-Til-Lit SMD LED technology)
- ◊ LED mimic diagram
- ◊ SMS messaging capability with suitable GSM Modem
- ◊ PC software is MS Windows based and allows the operator to control the module from a remote location (P810 Software Kit necessary)
- ◊ Easy pushbutton controls
- ◊ System parameters can be adjusted manually from the front panel
- ◊ kVA, kW ve Cosφ measurements
- ◊ Communication with MODEM

### Pushbutton Controls

STOP / START  
 AUTO, TEST, MANUAL  
 LCD PAGE

### Input Functions display on LCD

Generator Volts	Volts L1-N, L2-N, L3-N
Generator Volts	Volts L1-L2, L2-L3, L3-L1
Generator Amps	Amps L1, L2, L3
Generator Frequency	Hz
Mains Volts	Volts L1-N, L2-N, L3-N
Mains Volts	Volts L1-L2, L2-L3, L3-L1
Mains Frequency	Hz
Engine Speed	RPM
Plant Battery Volts	Volts
Engine Hours Run	Hour
Generator total power	kVA L1, L2, L3, total
Generator total power	kW L1, L2, L3, total
Generator power factor	Cosφ L1, L2, L3, total

### Optional Input Functions

Engine Oil pressure	kPa
Fuel level	%
Engine Temperature	°C

### Alarm Channels

Under/over generator voltage  
 Over-current  
 Under/over generator frequency  
 Under/over speed  
 Charge fail  
 Emergency stop  
 Low oil pressure  
 High engine temperature  
 Fail to start  
 Low/high DC battery voltage  
 Reverse power  
 Generator phase rotation error  
 Generator short-circuit protection  
 Loss of speed sensing signal  
 Mains out of limits

### Environmental Testing Standards

#### Electromagnetic Compatibility

BS EN 50081-2:1992 and EN 61000-6-4:2000 EMC, Emission Standards for the Industrial Environment

EN 61000-6-2:1999 EMC, Immunity Standards for the Industrial Environment

#### Vibration

BS EN 60068-2-6 Ten sweeps (up and back down) at 1 octave/minute in each of the three major axes.

5Hz to @ +/-7.5mm constant displacement.

8Hz to 500Hz 2gn constant acceleration.

#### Temperature

Cold : BS EN 60068-2-1 to -30°C

Hot : BS EN 60068-2-2 to 70°C

#### Humidity

BS EN 2011 part 2.1 93% RH @ 40° for 48 hours

#### Shock

BS EN 6068-2-27 Three half sine shocks in each of the three major axes 15gn amplitude.11ms duration.

#### Electrical Safety

BS EN 60950 Low Voltage Directive/Safety of information technology equipments, including electrical business equipment

**Model Codes and General Information**

Cukurova Diesel Generator

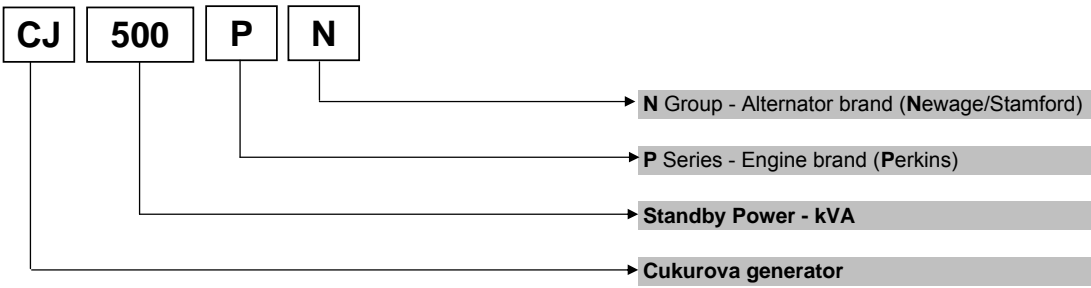

Perkins 2500 Series Diesel Engine

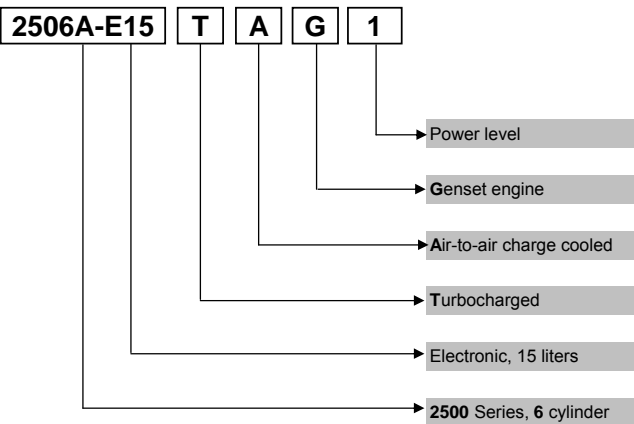

Newage/Stamford Alternator

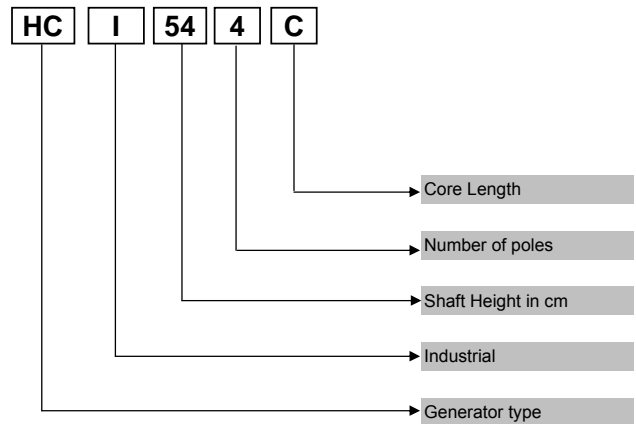

**Information**

**Power Ratings**

**Standby power rating** is for the supply of emergency power at variable load for the duration of the non-availability of the mains power supply.No overload capacity is available at this rating.A standby rated engine should be sized for an average load factor of 80% based on published standby rating for 500 operating hours per year.Standby ratings should never be applied except in true emergency power failure conditions.

**Prime power rating** is available for unlimited hours per year with a variable load of which the average engine load factor is 80% of the published power rating, incorporation of a 10% overload for 1 hour in every 12 hours of operation which permitted

**Continuous power rating** is available for continuous full load operation.No overload is permitted.

Acc. To ISO 3046/1, BS 5514, DIN6271

**Electric Formulas**

Values	Formula	
kWe	kWm X E	
kWe	$(U \times I \times 1.73 \times pf) / 1000$	kVA x pf
kVA	$(U \times I \times 1.73) / 1000$	kWe / pf
I (Amp)	$(kWe \times 1000) / (U \times 1.73 \times pf)$	$(kVA \times 1000) / (U \times 1.73)$
Frequency	$(Rpm \times N^{\circ}Pole) / (2 \times 60)$	
Rpm	$(2 \times 60 \times Frequency) / N^{\circ}Pole$	

**kWm**: Mechanical Power

**kWe** : Electrical Power

**pf** : Power factor

**E** : Alternator efficiency

**I** : Current (A)

**U** : Voltage (V)

**kVA** : Power

**Rpm**: Revolutions per minute

**General Dimensions**

Standard Generator

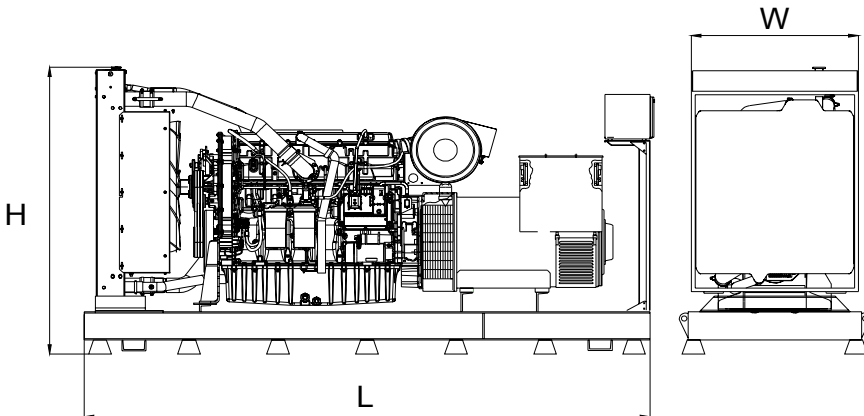

<b>Length, L</b>	3,75 m
<b>Height, H</b>	2,05 m
<b>Width, W</b>	1,1 m
<b>Weight, Total</b>	3650 kg

Generator with Soundproof Canopy

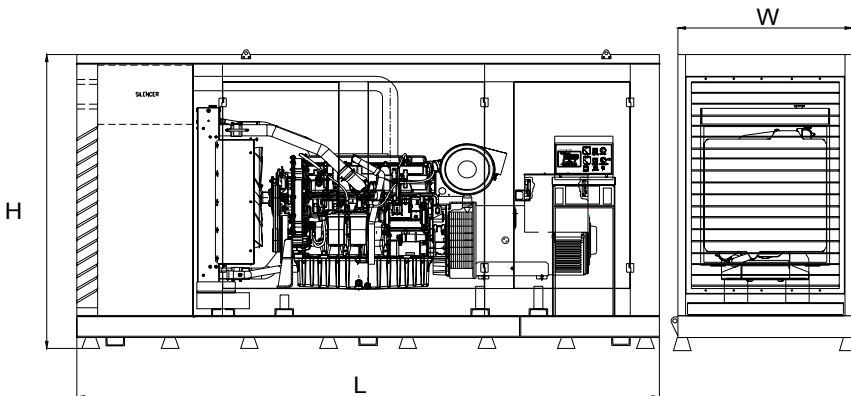

<b>Length, L</b>	5 m
<b>Height, H</b>	2,8 m
<b>Width, W</b>	1,5 m
<b>Weight, Total</b>	5350 kg

**Generator Room Layout**

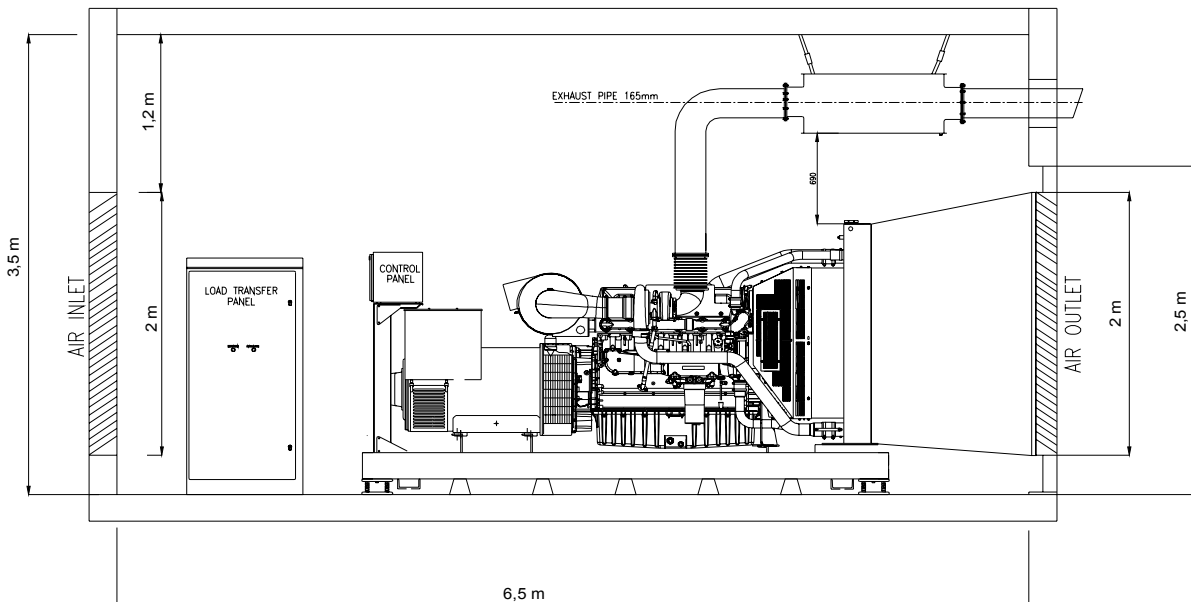

*Above drawings dimensions and weights are only for guidance. For installation design of your specific application, necessary certified drawings, at site consultancy service as well as maintenance and installations manuals will be provided by Cukurova without any charge.*

*Specifications may change without notice*

	<b>CUKUROVA JENERATOR SANAYII TICARET A.S.</b>	
	<p><b>Izmir Factory</b>                  Aegean Free Zone, Boss Sokak                  No:11, Gazimir - Izmir, Turkey                  Tel : +90 232 252 2026                  Fax : +90 232 252 2027</p>	<p><b>Istanbul Export Sales Office</b>                  Ankara Yolu, Tuzla Tersane Kavşagi                  No:26 34947 Tuzla-Istanbul, Turkey                  Tel : +90 216 395 3460                  Fax : +90 216 395 5453                  Mail : info@cukurovapower.com</p>