

Perkins 2506A-E15TAG2 diesel engine

Newage/Stamford HCI544D alternator

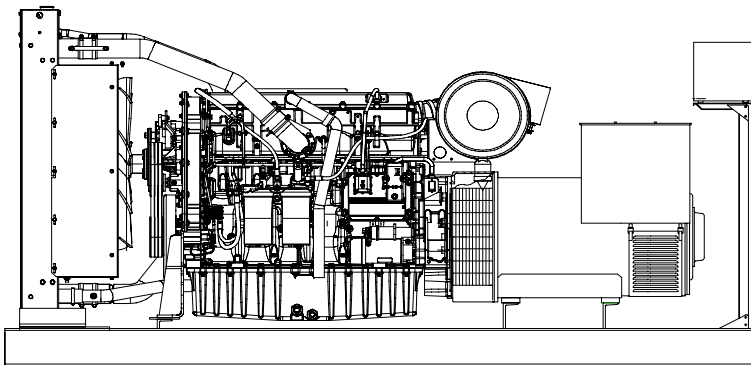

Standard Generator Features

- ◊ AMF, Automatic mains failure unit
- ◊ Heavy duty type, 6 cylinder, water cooled engine
- ◊ 50°C tropical type radiator
- ◊ Starter motor
- ◊ Lead acid battery
- ◊ Charging alternator
- ◊ Battery charge redressor
- ◊ Heavy duty, brushless type alternator
- ◊ Base frame with anti-vibration units
- ◊ Industrial type silencers
- ◊ Flexible exhaust compensator
- ◊ Block water heater unit
- ◊ Control panel with digital-automatic main control module
- ◊ Fan, fan drive, charging alternator drive and all rotating parts covered
- ◊ Radiator matrix covered by metal mesh against the mechanical damages
- ◊ Fabricated and welded steel base frame
- ◊ Anti-vibration mountings
- ◊ Engine and alternator manufacturer test reports
- ◊ Factory load, performance and function tests

Optional Features

- ◊ Automatic load transfer panel
- ◊ Automatic synchronization and power sharing systems
- ◊ Soundproof canopy
- ◊ Container type enclosures
- ◊ Road trailer
- ◊ Job-site trailer
- ◊ Protection circuit breaker
- ◊ Air start
- ◊ Remote type radiator
- ◊ Base fuel tank
- ◊ External type fuel tank
- ◊ Automatic fuel transfer system
- ◊ Residential silencer



| Model | Standby | | Prime | |
|----------------|------------|------------|------------|------------|
| | kVA | kW | kVA | kW |
| CJ550PN | 562 | 450 | 511 | 409 |

APPLICATION DATA

Perkins 2506A-E15TAG2 Engine

Standard Features

Economic power

◊Mechanically operated unit fuel injectors with advanced electronic control, combined with carefully matched turbocharging, give excellent fuel atomisation which leads to exceptional low fuel consumption.

Reliable power

◊Developed and tested using the latest engineering techniques and finite element analysis for high reliability.
 ◊Low oil usage and low wear rates.
 ◊High compression ratio ensures clean rapid starting in all conditions.
 ◊Support comes from a worldwide network of 4,000 distributors and dealers.

Compact, clean and efficient power

◊Exceptional power to weight ratio and compact size gives optimum power density for ease of installation and more cost effective transportation.
 ◊Designed to provide excellent service access for ease of maintenance.

Standards

◊ UK MOD, BS5750, ISO9001, BS5514/1-1982, ISO 3046/1, ISO 8528/1

Technical Specifications

| | |
|---|--|
| Manufacturer | PERKINS |
| Model | 2506A-E15TAG2 |
| Type | 4 cycle, water-cooled, diesel engine |
| Number of cylinders | 6 |
| Cylinder arrangement | Vertical in-line |
| Displacement, Liters | 15.2 |
| Bore X Stroke, mm | 137 X 171 |
| Compression Ratio | 16:1 |
| Combustion System | Direct injection |
| Aspiration | Turbocharged, air-to-air charge cooled |
| Rotation | Anti-clockwise viewed on flywheel |
| Gross engine power, kWb | 495 |
| Fan Power, kWm | 17 |
| BMEP gross, bar | 26,82 |
| Combustion air flow, m ³ / min | 32 |
| Exhaust gas temp.(after turbo), °C | 528 |
| Exhaust gas flow (after turbo),m ³ / min | 87 |
| Mean piston speed, m / s | 8 |

Cooling System

| | |
|---|---------------------------|
| Type | Tropical, heavy duty type |
| Ambient temperature, °C | 50 |
| Engine+Radiator coolant cap., Liters | 58 |
| Jacket coolant flow, Liters / sec | 5.2 |
| Cooling min airflow, m ³ / min | 576 (at 48°C) |
| ◊Gear-driven circulating pump | |
| ◊Mounted belt-driven pusher fan | |
| ◊Radiator supplied loose incorporating air-to-air charge cooler | |
| ◊System designed for ambients up to 50°C | |

| Model | Standby kW | | Prime kW | |
|----------------------|------------|------------|------------|------------|
| | Gross | Net | Gross | Net |
| 2506A-E15TAG2 | 503 | 478 | 459 | 435 |

Lubricating System

| | |
|---|-------------|
| Type | Pressurized |
| Capacity, Liters | 62 |
| Lub oil pressure (min), kPa | 200 |
| ◊Wet sump with filler and dipstick | |
| ◊Full-flow replaceable 'Ecoplus' filter | |
| ◊Oil cooler integral with filter header | |

Fuel System

| | |
|---|--|
| Type of injection system | MEUI |
| Fuel injector | MEUI |
| Delivery/hour at 1500rev/min, Liters | 413 |
| Governor type | Electronic, governing to ISO 8528-5 class G3 |
| ◊Mechanically actuated electronically controlled unit fuel injectors with full authority electronic control | |
| ◊Replaceable 'Ecoplus' fuel filter elements with primary filter/water separator | |
| ◊Fuel cooler | |

Electrical System

| | |
|--|---------------------------------|
| Alternator | 24 Volt with integral regulator |
| Starter motor (DC) | 24 Volt |
| Starter motor power | 7.5 kW |
| ◊ECM mounted on engine with wiring looms and sensors | |
| ◊3 level engine protection system | |

Fuel Consumption

| | | |
|-----------------|-----------|-----------|
| liters per hour | %110 Load | 111 L |
| | %100 Load | 107 L |
| | %75 Load | 75 L |
| | %50 Load | 53.5 L |
| grams per kWh | %110 Load | 200 g/kWh |
| | %100 Load | 202 g/kWh |
| | %75 Load | 199 g/kWh |
| | %50 Load | 205 g/kWh |

Optional Equipments

- ◊Additional speed sensor
- ◊Temperature and pressure sensors for gauges
- ◊Air filter rain hood
- ◊Twin starters/facility for second starter
- ◊Closed circuit crankcase ventilation system

Newage/Stamford HCI544D Alternator

Standard Features

Winding&Electrical Performance

All generator stators are wound to 2/3 pitch. This eliminates triplen (3rd, 9th, 15th...) harmonics on the voltage waveform and is found to be the optimum design for trouble-free supply of non-linear loads. The 2/3 pitch design avoids excessive neutral currents sometimes seen with higher winding pitches, when in parallel with the mains. A fully connected damper winding reduces oscillations during paralleling. This winding, with the 2/3 pitch and carefully selected pole and tooth designs, ensures very low waveform distortion.

SX440 AVR

With this self-excited system the main stator provides power via the Automatic Voltage Regulator (AVR) to the exciter stator. The high efficiency semi-conductors of the AVR ensure positive build-up from initial low levels of residual voltage.

The exciter rotor output is fed to the main rotor through a three-phase full-wave bridge rectifier. The rectifier is protected by a surge suppressor against surges caused, for example, by short circuit or out-of-phase paralleling.

The SX440 will support a range of electronic accessories, including a 'droop' Current Transformer (CT) to permit parallel operation with other ac generators. If 3-phase sensing is required with the self-excited system, the SX421 AVR must be used.

Terminals&Terminal Box

Standard generators are 3-phase reconnectable with 12 ends brought out to the terminals, which are mounted on a cover at the non-drive end of the generator. A sheet steel terminal box contains the AVR and provides ample space for the customer's wiring and gland arrangements. It has removable panels for easy access.

Shaft&Keys

All generator rotors are dynamically balanced to better than BS6861:Part 1 Grade 2.5 for minimum vibration in operation. Two bearing generators are balanced with a half key.

Insulation / Impregnation

The insulation system is class 'H'

All wound components are impregnated with materials and processes designed specifically to provide the high build required for static windings and the high mechanical strength required for rotating components.

Standards

Newage Stamford industrial generators meet the requirements of **BS EN 60034** and the relevant section of other international standards such as **BS5000, VDE0530, NEMA MG1-32, IEC34, CSA C22.2-100, AS1359**. Other standards and certifications can be considered on request.

Quality Assurance

Generators are manufactured using production procedures having a quality assurance level to BS EN ISO 9001.

| Model | Standby | | Prime | |
|----------------|------------|------------|------------|------------|
| | kVA | kW | kVA | kW |
| HCI544D | 590 | 472 | 550 | 440 |

Technical Specifications

| | |
|--|--|
| Manufacturer | NEWAGE / STAMFORD |
| Model | HCI544D |
| Type | 4-Poles, Rotating Field, Brushless |
| Standby power at rated voltage, kVA | 590 |
| Efficiency, % | 94% |
| Power factor | 0.8 |
| Phase | 3 |
| Frequency, Hz | 50 |
| Speed, Rpm | 1500 |
| Voltage, V | 380/415 |
| Excitation | Self excited |
| Stator windings | 2/3 Pitch factor |
| Regulation | AVR, Automatic Voltage Regulator |
| Voltage Regulator | SX440 |
| Voltage Regulation, % | ± 1 |
| R.F.I Suppression | BS EN 61000-6-2 & BS EN 61000-6-4 VDE0875G, VDE 0875N |
| Waveform distortion | No Load <1.5% Non distorting balanced linear load <5.0% |
| Rotor | Dynamic balanced |
| Overspeed, Rpm | 2250 |
| Short circuit current | < 300% |
| TIF | Less than 50 |
| Insulation class | H |
| Construction | Single bearing, direct coupled |
| Coupling | Flexible |
| Stator winding | Double layer concentric |
| Connection | WYE |
| Protection class | IP23 |
| Cooling air volume, m ³ / sec | 1.035 |

Optional Equipment

- ◊Optional Permanent Magnet Generator (PMG) provides an isolated power supply to the excitation control system
- ◊Anti Condensation Heaters
- ◊Air Filters
- ◊Temperature Indication RTD's
- ◊Winding Protection Thermistors
- ◊Quadrature Droop kit for Parallel Operation
- ◊SX421 AVR with 3 Phase Sensing and improved Regulation 0.5%
- ◊MX341 (PMG) 1% Regulation with 2 Phase Sensing
- ◊MX321 (PMG) with 3 Phase Sensing and improved Regulation 0.5%

Control Panel

Standard Equipments

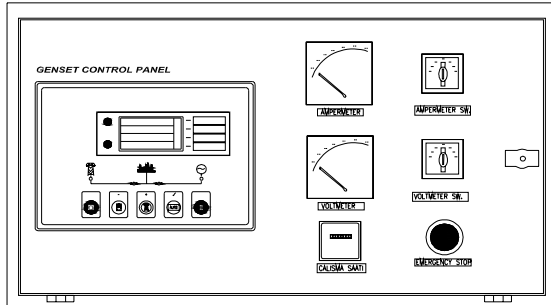

- ◊ Deepsea 5220 digital automatic control module
- ◊ Hourmeter
- ◊ Voltmeter
- ◊ Voltmeter commutator
- ◊ Amperemeter
- ◊ Amperemeter commutator
- ◊ Emergency stop button

Deepsea 5220 Control Module

Description

- ◊ The model 5220 is an Automatic Mains Failure Control module.
- ◊ The modul is used to monitor a mains supply and automatically start a standby generator set.
- ◊ The module also provides indication of operational status and fault conditions automatically shutting down the genset and indicating failures by means of an LCD display, and appropriate flashing LED on the front panel.
- ◊ Selected timers and alarms can be altered by the user from the front panel.
- ◊ Alterations to the system are made using the 810 interface and a PC. This interface also provides real time diagnostic facilities

Specifications

- ◊ 240mm x 172mm dimensions
- ◊ 70mm x 40mm dimensions, 4 segment grafical LCD monitor
- ◊ Developed 16-bit Microprocessor design
- ◊ Easy comprehended display (Hid-Til-Lit SMD LED technology)
- ◊ LED mimic diagram
- ◊ SMS messaging capability with suitable GSM Modem
- ◊ PC software is MS Windows based and allows the operator to control the module from a remote location (P810 Software Kit necessary)
- ◊ Easy pushbutton controls
- ◊ System parameters can be adjusted manually from the front panel
- ◊ kVA, kW ve Cosφ measurements
- ◊ Communication with MODEM

Pushbutton Controls

STOP / START
 AUTO, TEST, MANUAL
 LCD PAGE

Input Functions display on LCD

| | |
|------------------------|---------------------------|
| Generator Volts | Volts L1-N, L2-N, L3-N |
| Generator Volts | Volts L1-L2, L2-L3, L3-L1 |
| Generator Amps | Amps L1, L2, L3 |
| Generator Frequency | Hz |
| Mains Volts | Volts L1-N, L2-N, L3-N |
| Mains Volts | Volts L1-L2, L2-L3, L3-L1 |
| Mains Frequency | Hz |
| Engine Speed | RPM |
| Plant Battery Volts | Volts |
| Engine Hours Run | Hour |
| Generator total power | kVA L1, L2, L3, total |
| Generator total power | kW L1, L2, L3, total |
| Generator power factor | Cosφ L1, L2, L3, total |

Optional Input Functions

| | |
|---------------------|-----|
| Engine Oil pressure | kPa |
| Fuel level | % |
| Engine Temperature | °C |

Alarm Channels

Under/over generator voltage
 Over-current
 Under/over generator frequency
 Under/over speed
 Charge fail
 Emergency stop
 Low oil pressure
 High engine temperature
 Fail to start
 Low/high DC battery voltage
 Reverse power
 Generator phase rotation error
 Generator short-circuit protection
 Loss of speed sensing signal
 Mains out of limits

Environmental Testing Standards

Electromagnetic Compatibility

BS EN 50081-2:1992 and EN 61000-6-4:2000 EMC, Emission Standards for the Industrial Environment

EN 61000-6-2:1999 EMC, Immunity Standards for the Industrial Environment

Vibration

BS EN 60068-2-6 Ten sweeps (up and back down) at 1 octave/minute in each of the three major axes.

5Hz to @ +/-7.5mm constant displacement.

8Hz to 500Hz 2gn constant acceleration.

Temperature

Cold : BS EN 60068-2-1 to -30°C

Hot : BS EN 60068-2-2 to 70°C

Humidity

BS EN 2011 part 2.1 93% RH @ 40° for 48 hours

Shock

BS EN 6068-2-27 Three half sine shocks in each of the three major axes 15gn amplitude.11ms duration.

Electrical Safety

BS EN 60950 Low Voltage Directive/Safety of information technology equipments, including electrical business equipment

Model Codes and General Information

Cukurova Diesel Generator

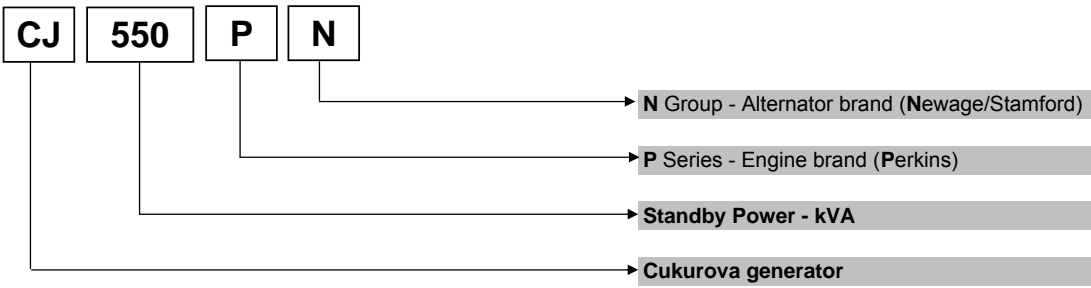

Perkins 2500 Series Diesel Engine

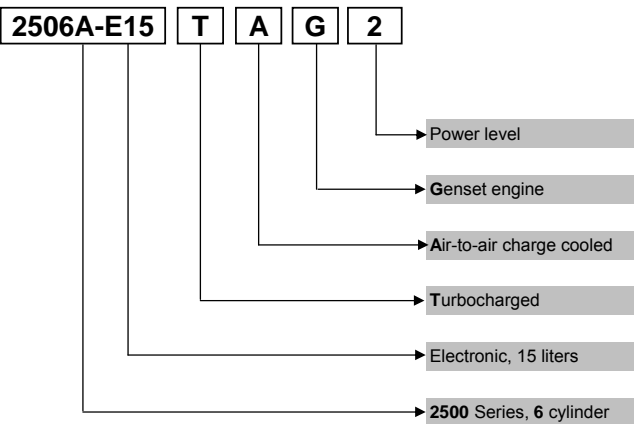

Newage/Stamford Alternator

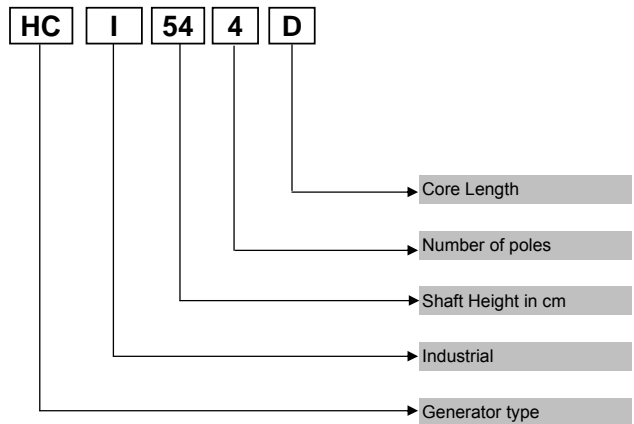

Information

Power Ratings

Standby power rating is for the supply of emergency power at variable load for the duration of the non-availability of the mains power supply.No overload capacity is available at this rating.A standby rated engine should be sized for an average load factor of 80% based on published standby rating for 500 operating hours per year.Standby ratings should never be applied except in true emergency power failure conditions.

Prime power rating is available for unlimited hours per year with a variable load of which the average engine load factor is 80% of the published power rating, incorporation of a 10% overload for 1 hour in every 12 hours of operation which permitted

Continuous power rating is available for continuous full load operation.No overload is permitted.

Acc. To ISO 3046/1, BS 5514, DIN6271

Electric Formulas

| Values | Formula | |
|-----------------|--|---------------------------------------|
| kW _e | kW _m X E | |
| kW _e | $(U \times I \times 1.73 \times pf) / 1000$ | kVA x pf |
| kVA | $(U \times I \times 1.73) / 1000$ | kW _e / pf |
| I (Amp) | $(kW_e \times 1000) / (U \times 1.73 \times pf)$ | $(kVA \times 1000) / (U \times 1.73)$ |
| Frequency | $(Rpm \times N^\circ Pole) / (2 \times 60)$ | |
| Rpm | $(2 \times 60 \times Frequency) / N^\circ Pole$ | |

kW_m: Mechanical Power

kW_e: Electrical Power

pf: Power factor

E: Alternator efficiency

I: Current (A)

U: Voltage (V)

kVA: Power

Rpm: Revolutions per minute

General Dimensions

Standard Generator

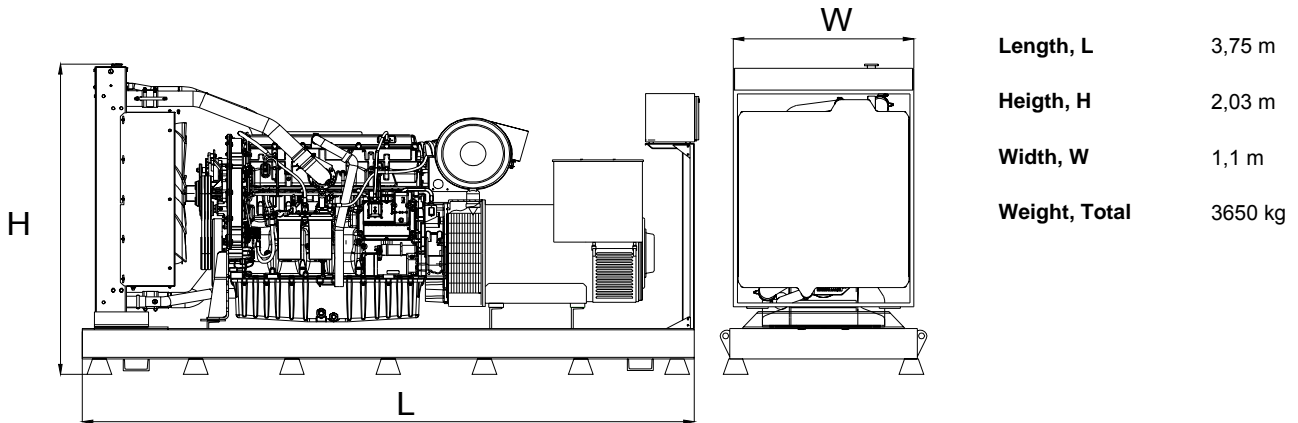

Generator with Soundproof Canopy

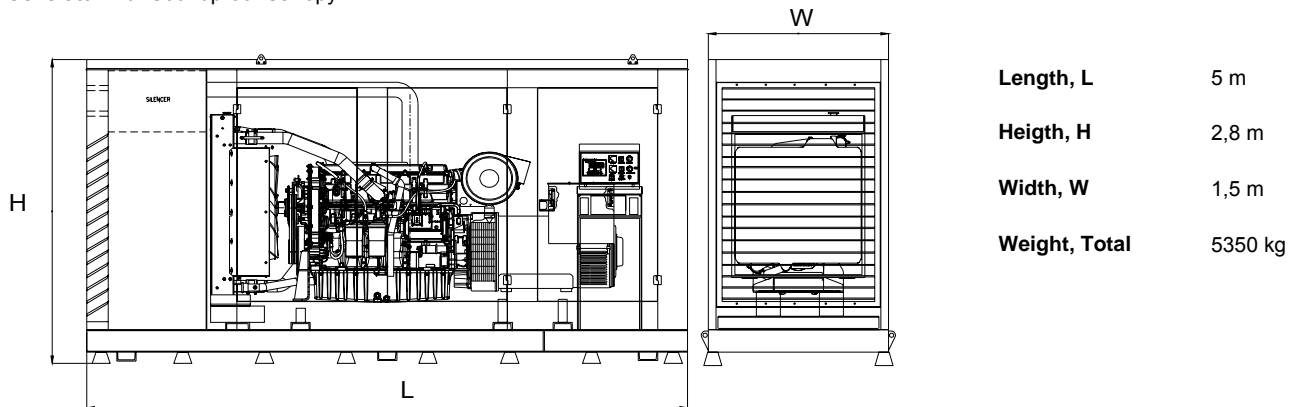

Generator Room Layout

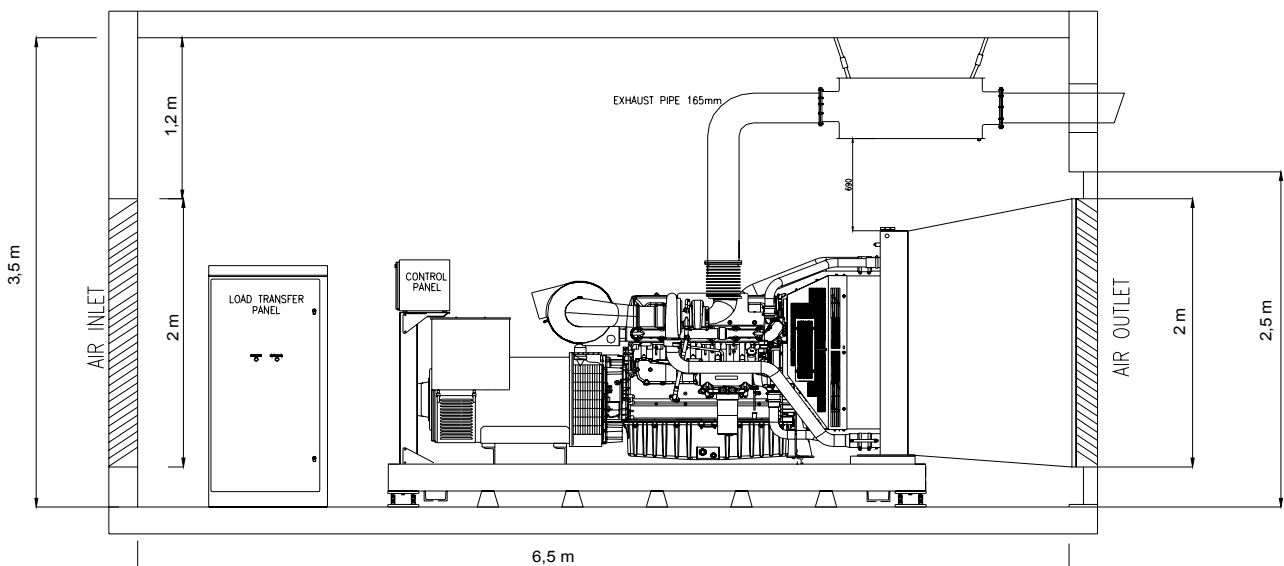

Above drawings dimensions and weights are only for guidance. For installation design of your specific application, necessary certified drawings, at site consultancy service as well as maintenance and installations manuals will be provided by Cukurova without any charge.

Specifications may change without notice

| | | |
|--|---|---|
| | CUKUROVA JENERATOR SANAYII TICARET A.S. | |
| | <p>Izmir Factory Aegean Free Zone, Boss Sokak No:11, Gazimir - Izmir, Turkey Tel : +90 232 252 2026 Fax : +90 232 252 2027</p> | <p>Istanbul Export Sales Office Ankara Yolu, Tuzla Tersane Kavşagi No:26 34947 Tuzla-Istanbul, Turkey Tel : +90 216 395 3460 Fax : +90 216 395 5453 Mail : info@cukurovapower.com</p> |