

CUKUROVA GENERATOR SYSTEMS

1500 Rpm, 50Hz, 400V

Volvo TD520GE diesel engine

Newage/Stamford UCI224G alternator

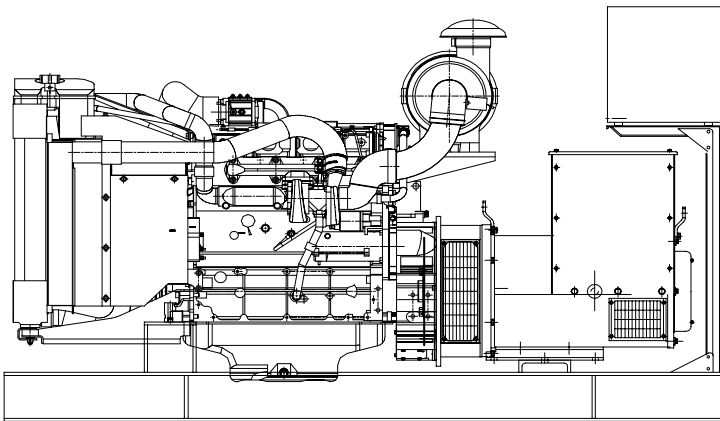

Standard Generator Features

- ◊ AMF, Automatic mains failure unit
- ◊ Heavy duty type, 4 cylinder, water cooled engine
- ◊ 60°C tropical type radiator
- ◊ Starter motor
- ◊ Lead acid battery
- ◊ Charging alternator
- ◊ Battery charge redressor
- ◊ Heavy duty, brushless type alternator
- ◊ Base frame with anti-vibration units
- ◊ Industrial type silencers
- ◊ Flexible exhaust compensator
- ◊ Block water heater unit
- ◊ Control panel with digital-automatic main control module
- ◊ Fan, fan drive, charging alternator drive and all rotating parts covered
- ◊ Radiator matrix covered by metal mesh against the mechanical damages
- ◊ Fabricated and welded steel base frame
- ◊ Anti-vibration mountings
- ◊ Engine and alternator manufacturer test reports
- ◊ Factory load, performance and function tests

Optional Features

- ◊ Automatic load transfer panel
- ◊ Automatic synchronization and power sharing systems
- ◊ Soundproof canopy
- ◊ Container type enclosures
- ◊ Road trailer
- ◊ Job-site trailer
- ◊ Protection circuit breaker
- ◊ Air start
- ◊ Remote type radiator
- ◊ Base fuel tank
- ◊ External type fuel tank
- ◊ Automatic fuel transfer system
- ◊ Residential silencer



Model	Standby		Prime	
	kVA	kW	kVA	kW
CJ90VN	91	73	84	67

APPLICATION DATA

Volvo TD520GE Engine

Standard Features

The TD520GE is a powerful, reliable and economical Generating Set Diesel built on the dependable in-line four design.

Durability & low noise

Designed for easiest, fastest and most economical installation. Well-balanced to produce smooth and vibration-free operation with low noise level.

Low exhaust emission

The state of the art, high-tech injection and charging system with low internal losses contributes to excellent combustion and low fuel consumption.

The TD520GE complies with **EPA/CARB Tier 1** and **TA-Luft** exhaust emission regulations.

Easy service & maintenance

Easily accessible service and maintenance points contribute to the ease of service of the engine.

Technical Description

- ◊Closed crankcase ventilation system
- ◊Single gray cast iron cylinder head
- ◊Optimized gray cast iron crankcase
- ◊Gear train on flywheel side
- ◊Crankshaft with integrated counter weights with five main bearings
- ◊Wet, replaceable cylinder liners
- ◊Efficient and reliable turbo charger
- ◊Belt driven efficient coolant pump
- ◊Integrated full flow oil cooler
- ◊Air filter with replaceable insert
- ◊All service points on the right hand side

Technical Specifications

Manufacturer	VOLVO
Model	TD520GE
Type	4 cycle, water-cooled, diesel engine
Number of cylinders	4
Cylinder arrangement	In-line
Displacement, Liters	4.76
Bore X Stroke, mm	108 X 130
Compression Ratio	17.5:1
Combustion System	Direct injection
Aspiration	Turbocharged
Rotation	Anti-clockwise viewed towards flywheel
Gross engine power, kWb	85
Fan Power, kWm	2.5
BMEP gross, bar	14
Combustion air flow, m ³ / min	4.75
Exhaust gas temp.(after turbo), °C	610
Exhaust gas flow (after turbo),m ³ / min	15.4
Mean piston speed, m / s	6.5

Model	Standby kW		Prime kW	
	Gross	Net	Gross	Net
TD520GE	85	82.5	77.5	75

Cooling System

Type	Tropical, heavy duty type
Ambient temperature, °C	60
Engine+Radiator coolant cap., Liters	17.5
Jacket coolant flow, Liters / sec	2.72
Cooling min airflow, m ³ / min	132 (at 60°C)
◊Efficient cooling system thermostatically controlled	
◊Belt driven coolant pump	
◊Fan guard	
◊Belt guard	

Fuel System

Type of injection system	Direct injection
Fuel injection pump	Bosh single injection pump
Total Fuel flow, Liter/h	360
Governor type	Heinzmann
◊Fuel filters of spin on type and fuel pre-filter with water separator standard	
◊Prefilter delivered loose	
◊Bosh single injection pump, pressure 1100-1300 bars for low emissions and low fuel consumption	

Fuel Consumption

liters per hour	%100 Load	19,6 L
	%75 Load	14.4 L
	%50 Load	9.6 L
grams per kWh	%100 Load	213 g/kWh
	%75 Load	208 g/kWh
	%50 Load	213 g/kWh

Lubricating System

Type	Pressurized
Capacity, Liters	13
Lub oil pressure , bar	4
◊Oil dipstick	
◊Full flow disposable spin-on oil filter, for extra high filtration	
◊Rotary type lubricating oil pump driven by crankshaft	

Electrical System

Alternator	Bosh, 12 Volt, 55Amp
Starter motor (DC)	Bosh / EV
Starter motor power	3.1 kW

Newage/Stamford UCI224G Alternator

Standard Features

Winding&Electrical Performance

All generator stators are wound to 2/3 pitch. This eliminates triplen (3rd, 9th, 15th...) harmonics on the voltage waveform and is found to be the optimum design for trouble-free supply of non-linear loads. The 2/3 pitch design avoids excessive neutral currents sometimes seen with higher winding pitches, when in parallel with the mains. A fully connected damper winding reduces oscillations during paralleling. This winding, with the 2/3 pitch and carefully selected pole and tooth designs, ensures very low waveform distortion.

SX460 AVR

With this self excited control system the main stator supplies power via the Automatic Voltage Regulator (AVR) to the exciter stator. The high efficiency semiconductors of the AVR ensure positive build-up from initial low levels of residual voltage.

This exciter rotor output is fed to the main rotor through a three phase full wave bridge rectifier. This rectifier is protected by a surge suppressor against surges caused, for example, by short circuit.

Terminals&Terminal Box

Standard generators are 3-phase reconnectable with 12 ends brought out to the terminals, which are mounted on a cover at the non-drive end of the generator. A sheet steel terminal box contains the AVR and provides ample space for the customer's wiring and gland arrangements. It has removable panels for easy access.

Shaft&Keys

All generator rotors are dynamically balanced to better than BS6861:Part 1 Grade 2.5 for minimum vibration in operation. Two bearing generators are balanced with a half key.

Insulation / Impregnation

The insulation system is class 'H'

All wound components are impregnated with materials and processes designed specifically to provide the high build required for static windings and the high mechanical strength required for rotating components.

Standards

Newage Stamford industrial generators meet the requirements of **BS EN 60034** and the relevant section of other international standards such as **BS5000, VDE0530, NEMA MG1-32, IEC34, CSA C22.2-100, AS1359**. Other standards and certifications can be considered on request.

Quality Assurance

Generators are manufactured using production procedures having a quality assurance level to BS EN ISO 9001.

Model	Standby		Prime	
	kVA	kW	kVA	kW
UCI224G	90.8	72.6	85	68

Technical Specifications

Manufacturer	NEWAGE / STAMFORD
Model	UCI224G
Type	4-Poles, Rotating Field, Brushless
Standby power at rated voltage, kVA	90.8
Efficiency, %	90
Power factor	0.8
Phase	3
Frequency, Hz	50
Speed, Rpm	1500
Voltage, V	380/415
Excitation	Self excited
Stator windings	2/3 Pitch factor
Regulation	AVR, Automatic Voltage Regulator
Voltage Regulator	SX460
Voltage Regulation, %	± 1.5
R.F.I Suppression	BS EN 61000-6-2 & BS EN 61000-6-4 VDE0875G, VDE 0875N
Waveform distortion	No Load <1.5% Non distorting balanced linear load <5.0%
Rotor	Dynamic balanced
Overspeed, Rpm	2250
Short circuit current	< 300%
TIF	Less than 50
Insulation class	H
Construction	Single bearing, direct coupled
Coupling	Flexible
Stator winding	Double layer concentric
Connection	WYE
Protection class	IP23
Cooling air volume, m ³ / sec	0.216

Optional Equipment

- ◊Optional Permanent Magnet Generator (PMG) provides an isolated power supply to the excitation control system
- ◊Anti Condensation Heaters
- ◊Air Filters
- ◊Temperature Indication RTD's
- ◊Winding Protection Thermistors
- ◊Quadrature Droop kit for Parallel Operation
- ◊SX440 AVR with 1% Regulation and 2 Phase Sensing
- ◊SX421 AVR with 3 Phase Sensing and improved Regulation 0.5%
- ◊MX341 (PMG) 1% Regulation with 2 Phase Sensing
- ◊MX321 (PMG) with 3 Phase Sensing and improved Regulation 0.5%

Control Panel

Standard Equipments

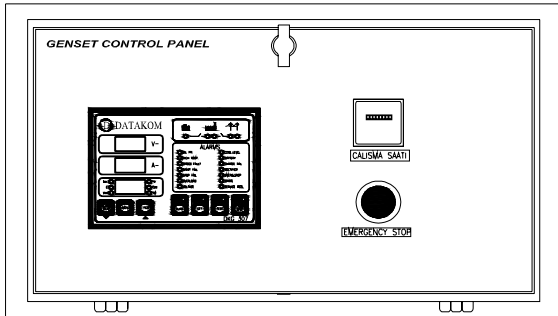

- ◊Datakom DKG307 digital automatic control module
- ◊Hourmeter
- ◊Emergency stop button

Datakom DKG307 Control Module

Description

- ◊The DKG-307 is a comprehensive AMF unit for a single generating set operating in standby mode.
- ◊In AUTOMATIC position, DKG-307 monitors mains phase voltages and controls the automatic starting, stopping and load transfer of the generating set in case of a mains failure and once the generator is running, it monitors internal protections and external fault inputs. If a fault condition occurs, the unit shuts down the engine automatically and indicates the failure source with the corresponding red led lamp.
- ◊The DKG-307 provides a comprehensive set of digitally adjustable timers, threshold levels, input and output configurations and operating sequences. The unauthorized access to program parameters is prevented by the program lock input. All programs may be modified via front panel pushbuttons, and do not require an external unit.
- ◊The fault conditions are considered in 2 categories as Warnings and Alarms. Measured values have separate programmable limits for warning and alarm conditions.
- ◊The service request indicator lamp turns on at the expiration of either engine hours or time limits.
- ◊It is possible to monitor the operation of the system locally or remotely with the WINDOWS based PC utility program.
- ◊The unit is designed for front panel mounting. It is fitted into the cut-out with the steel spring removed. Connections are made with 2 part plug and socket connectors.

Pushbutton Controls

STOP / START
 AUTO, TEST, MANUAL
 LCD PAGE

Features

- Automatic mains failure with genset control and protection
- Remote Start operation capability
- Analogue temperature and oil pressure inputs
- Genset KW and Power Factor measurement
- Engine hours run counter
- Periodic maintenance request display
- 165 programmable parameters
- Battery backed-up real time clock
- Weekly operation schedule programs
- Daily, weekly, monthly exerciser
- Event logging with time stamp
- Statistical counters
- Serial RS-232 data output for telemetry on PC
- Free MS-Windows remote monitoring SW
- Configurable analogue inputs: 2
- Configurable digital inputs: 7
- Configurable relay outputs: 2
- Output expansion capability
- Small dimensions (155x115x48mm)

Input Functions display on LCD

Generator Volts	Volts L1-N, L2-N, L3-N
Generator Volts	Volts L1-L2, L2-L3, L3-L1
Generator Amps	Amps L1, L2, L3
Generator Frequency	Hz
Mains Volts	Volts L1-N, L2-N, L3-N
Mains Volts	Volts L1-L2, L2-L3, L3-L1
Mains Frequency	Hz
Engine Speed	RPM
Plant Battery Volts	Volts
Engine Hours Run	Hour
Generator total power	kVA L1, L2, L3,total
Generator total power	kW L1, L2, L3,total
Generator power factor	Cosφ L1, L2, L3,total

Optional Input Functions

Engine Oil pressure	kPa
Fuel level	%
Engine Temperature	°C

Alarm Channels

- Under/over generator voltage
- Over-current
- Under/over generator frequency
- Under/over speed
- Charge fail
- Emergency stop
- Low oil pressure
- High engine temperature
- Fail to start
- Low/high DC battery voltage
- Reverse power
- Generator phase rotation error
- Generator short-circuit protection
- Loss of speed sensing signal
- Mains out of limits

Model Codes and General Information

Cukurova Diesel Generator

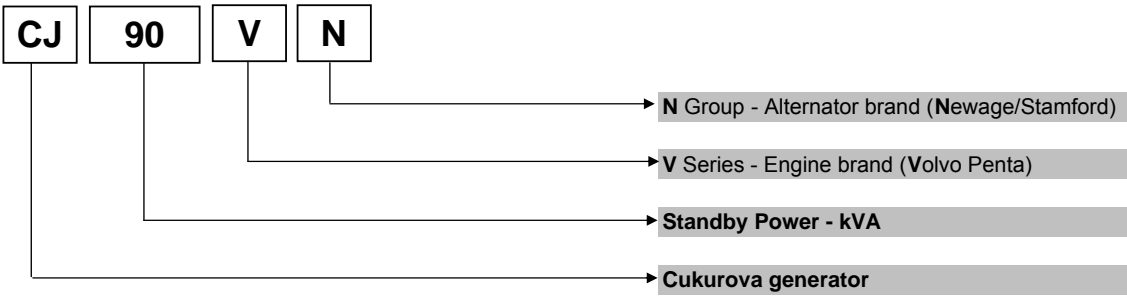

Volvo Penta Diesel Engine

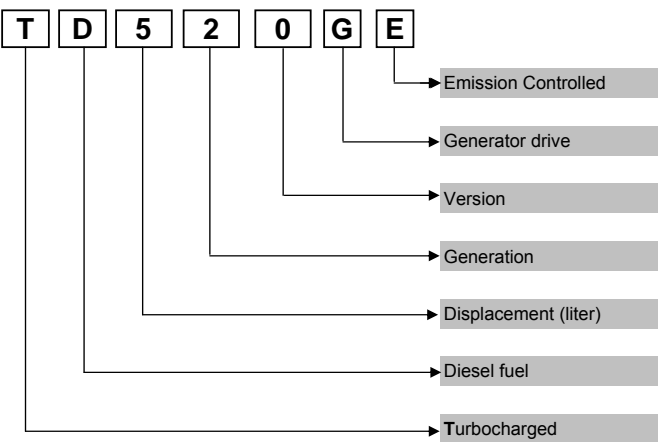

Newage / Stamford Alternator

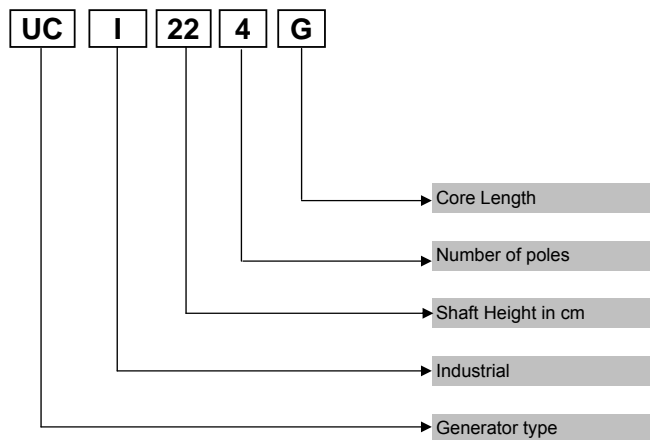

Information

Power Ratings

Standby power rating is for the supply of emergency power at variable load for the duration of the non-availability of the mains power supply. No overload capacity is available at this rating. A standby rated engine should be sized for an average load factor of 80% based on published standby rating for 500 operating hours per year. Standby ratings should never be applied except in true emergency power failure conditions.

Prime power rating is available for unlimited hours per year with a variable load of which the average engine load factor is 80% of the published power rating, incorporation of a 10% overload for 1 hour in every 12 hours of operation which permitted

Continuous power rating is available for continuous full load operation. No overload is permitted.

Acc. to ISO 3046/1, BS 5514, DIN6271

Electric Formulas

Values	Formula	
kWe	kWm X E	
kWe	$(U \times I \times 1.73 \times pf) / 1000$	kVA x pf
kVA	$(U \times I \times 1.73) / 1000$	kWe / pf
I (Amp)	$(kWe \times 1000) / (U \times 1.73 \times pf)$	$(kVA \times 1000) / (U \times 1.73)$
Frequency	$(Rpm \times N^{\circ}Pole) / (2 \times 60)$	
Rpm	$(2 \times 60 \times Frequency) / N^{\circ}Pole$	

- kWm: Mechanical Power
- kWe : Electrical Power
- pf : Power factor
- E : Alternator efficiency
- I : Current (A)
- U : Voltage (V)
- kVA : Power
- Rpm: Revolutions per minute

General Dimensions

Standard Generator

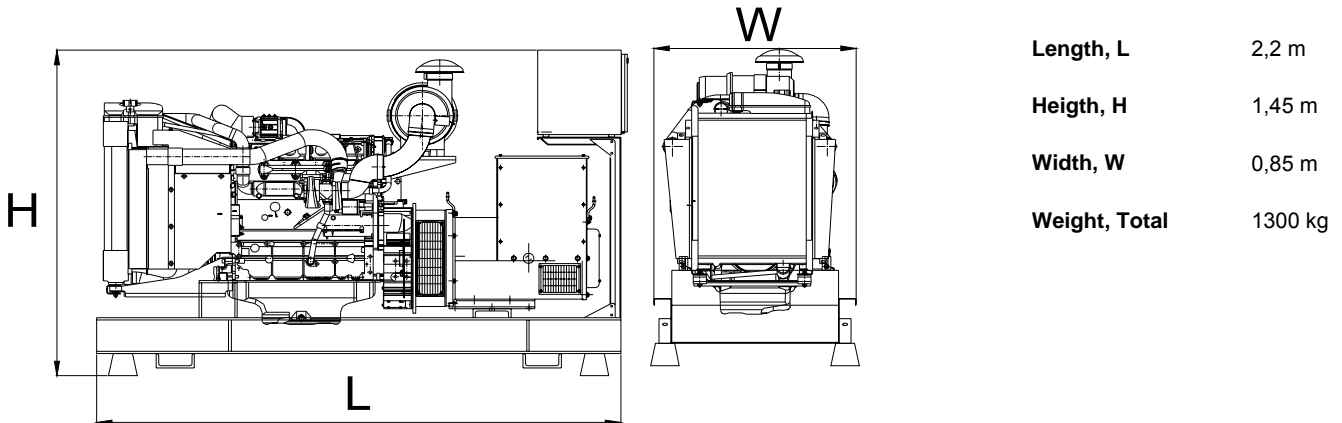

Generator with Soundproof Canopy

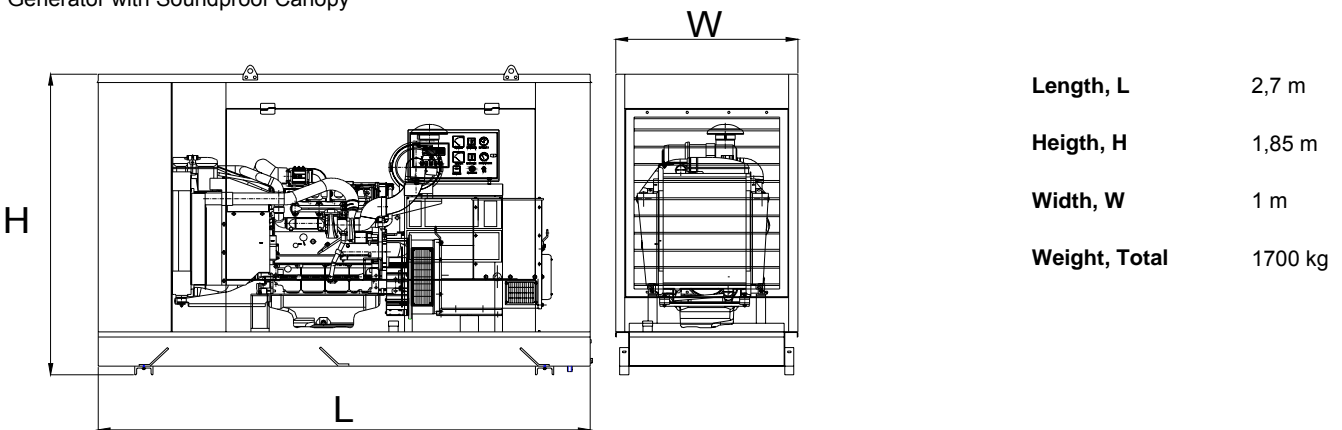

Generator Room Layout

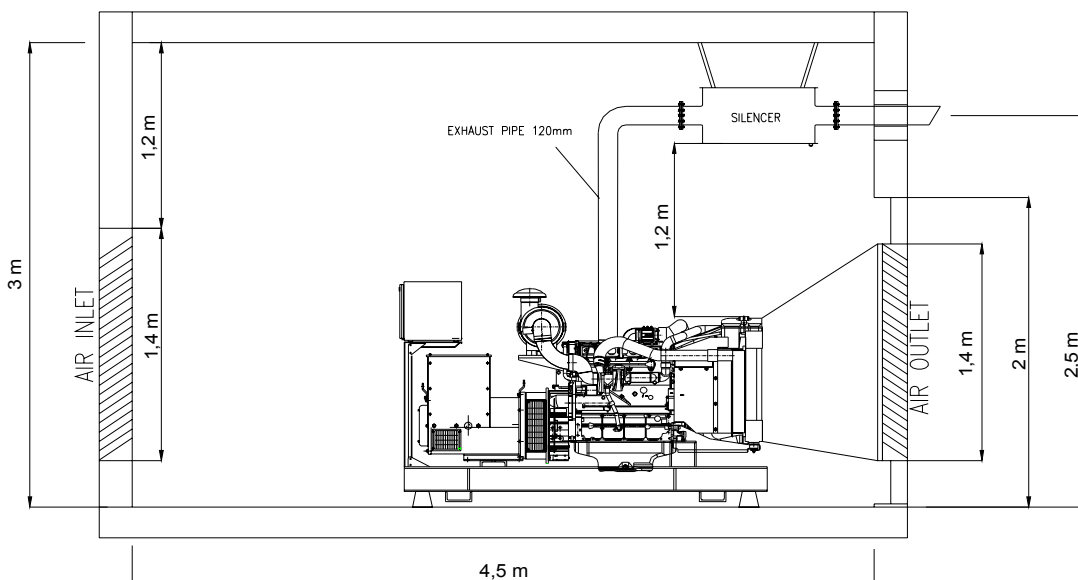

Above drawings dimensions and weights are only for guidance. For installation design of your specific application, necessary certified drawings, at site consultancy service as well as maintenance and installations manuals will be provided by Cukurova without any charge.

Specifications may change without notice

	<p>CUKUROVA JENERATOR SANAYII TICARET A.S.</p> <p><u>Izmir Factory</u> Aegean Free Zone, Boss Sokak No:11, Gazimir - Izmir, Turkey Tel : +90 232 252 2026 Fax : +90 232 252 2027</p>	<p><u>Istanbul Export Sales Office</u> Ankara Yolu, Tuzla Tersane Kavşagi No:26 34947 Tuzla-Istanbul, Turkey Tel : +90 216 395 3460 Fax : +90 216 395 5453 Mail : info@cukurovapower.com</p>
	<p>All information in this document is substantially correct at time of printing and may be altered subsequently.</p>	